

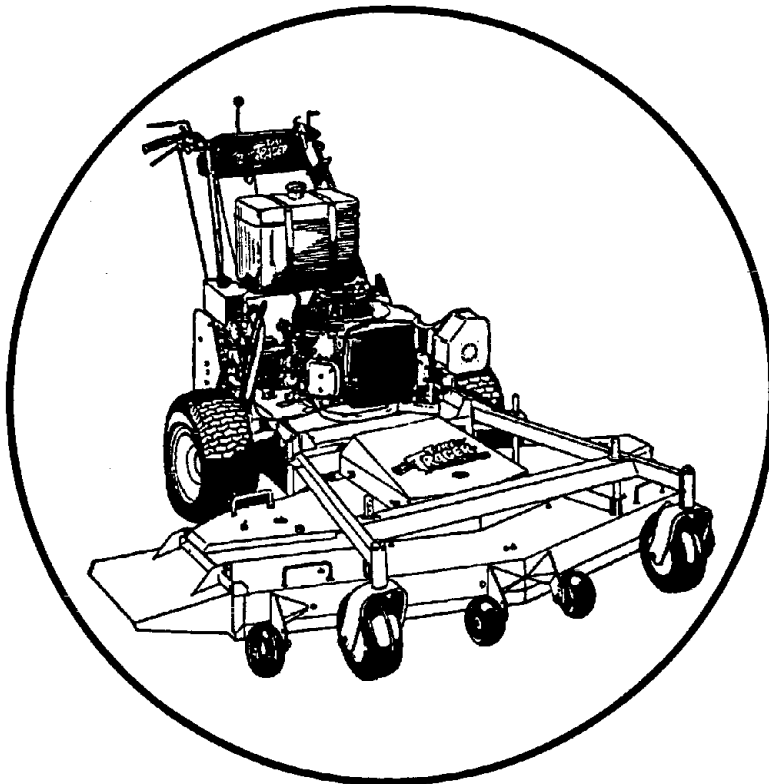

For Serial Nos.  
130,000 & Higher

# TURF TRACER HP



## Parts Manual

**CONGRATULATIONS** on the purchase of your new Exmark mower. This product has been carefully designed and manufactured to give you a maximum amount of dependability and years of trouble-free operation.

If additional information is needed, or should you require trained mechanic service, contact your authorized Exmark equipment dealer or distributor.

If you need to order replacement parts from your dealer, always give the model number and serial number of your mower as well as the part number, description and quantity of the part needed.

The Serial No. plate is located on the top front engine frame on the right hand side of the machine.

For ease of ordering and reference, we suggest that you record the information requested in the following identification table.

Model No. \_\_\_\_\_

Serial No. \_\_\_\_\_

Date Purchased \_\_\_\_\_

Purchased From \_\_\_\_\_

Paste Label From  
Literature Packet Here

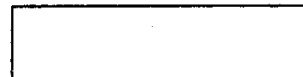

# EXMARK PARTS PLUS® PROGRAM

EFFECTIVE DATE: September 1, 1995

## Program

If your Exmark dealer does not have the Exmark part in stock, Exmark will get the parts to the dealer the next business day or the part will be FREE\* Guaranteed!!

## *How the Program Works*

1. If dealer does not have part in stock for a "down" unit at the time of request by customer, the dealer contacts his distributor by 1:00 p.m., local time, and requests Exmark Parts Plus® shipment of six (6) line items or less.
2. Distributor ships part(s) to dealer or customer, as requested by dealer, same day, overnight UPS. Distributor bills dealer for part and freight charges where applicable.
3. If distributor does not have the part(s) in stock to satisfy Exmark Parts Plus® order, he contacts Exmark by 3:00 p.m., central time, with an Exmark Parts Plus® order of six (6) line items or less.
4. If order is received by 3:00 p.m. central time, Exmark ships part(s) direct to dealer or customer, as requested by distributor, same day, overnight UPS. Exmark bills the distributor for parts and shipping charges, where applicable.
5. The customer pays for the part and freight if it is shipped under the Exmark Parts Plus® and if it arrive in accordance to the program.
6. Who pays for the part and freight if it fails to arrive overnight in accordance to the program?
  - A. Under any circumstance the customer does not pay.
  - B. If the part does not arrive overnight due to:
    1. The dealer not submitting the Exmark Parts Plus® order to his Exmark distributor by 1:00 p.m., the dealer pays for the part and freight.
    2. The Distributor being unable to ship the part the same day or not submitting the Exmark Parts Plus® order to Exmark by 3:00 p.m., central time, the Distributor pays for the part and freight.
    3. Exmark being unable to ship the part and the Exmark parts order is received by 3:00 p.m., central time, Exmark pays for the part and freight.
    4. If the part does not arrive overnight due to the shipper (UPS), the shipper pays for the freight and Exmark pays for the part.



**The following restrictions apply** -- The Exmark Parts Plus® Program is available only through participating Exmark Dealers and applies only to orders submitted on this program Monday through Thursday. UPS has initiated a Saturday delivery program to many areas of the continental United States and can be requested for an overnight shipment on Friday to be delivered Saturday. The next day air charge, plus the Saturday delivery fee will be the responsibility of the purchaser. Exmark Mfg. will assume no responsibility for Saturday delivery shipments. To qualify, all Exmark Parts Plus® orders must be received by Exmark by 3:00 p.m., central time. Orders must be six (6) line items or less. Exclusions from the Exmark Parts Plus® Program are: Any wholegood or accessory in its entirety, engines and engine replacement parts, 5-speed Peerless transmissions and 5-speed transaxles, hydraulic or hydrostatic wheel motors, cutter decks and engine decks or any item exceeding United Parcel Service size and weight restrictions.

Due to UPS restrictions, aerosol spray paint is considered a hazardous material and cannot be shipped via UPS next day or Second Day Air.

Exmark Manufacturing stocks a limited supply of parts for transaxles, pumps and wheel motors. These parts can be ordered for Next Day Air shipment but will not be guaranteed per the Parts Plus Program.



**READ OPERATOR'S MANUAL BEFORE  
OPERATING OR SERVICING EXMARK EQUIPMENT.**

## **TABLE OF CONTENTS**

<b><u>Description</u></b>	<b><u>Page</u></b>
Decals.....	14-15
Engine Deck Group .....	8-10
52" Mower Deck .....	6-7
48" Mower Deck .....	4-5
Hydraulics Group.....	11
36" Mower Deck .....	2-3
Upper Handles & Controls .....	12-13
Wiring Diagrams .....	16

## 36" MOWER DECK

Ref. No.	Part No.	Description	Qty. Req'd.	Ref. No.	Qty. Req'd.	Part No.	Description	Qty. Req'd.
1	414388	Shield, belt (413098) w/decals	1	36	1	413099	Pulley, idler	1
2	323385	Knob, belt shield	4	37	1	412134	Idler arm weldmt	1
3	323417	Washer, belt cover	4		1	414144	Idler arm weldmt w/bushings	1
4	414309	Support weldmt (412108)w/bushings, & decals	1	38	1	603384	Bushing, idler pivot	1
5	513338	Washer	2	39	1	613098	Pulley, idler	1
6	513336	Bushing, deck support	2	40	1	413113	Bushing, idler	1
7	806007	Hairpin, cotter	2	41	2	804256	Nut, 5/16-18 nylock	2
8	303164	Spacer	2	42	3	809001	Nut, 5/16-18 whizlock	3
9	603540	Link, rear deck support	2	43	2	800273	Screw, 5/16-18 x 1	2
10	800293	Screw, 3/8-16 x 1-1/4	8	44	2	603001	Rod, deck support	2
11	803031	Nut, 3/8-24	2	45	2	806332	Rollpin	2
12	808507	Ring, retaining	2	46	3	800270	Screw, 5/16-18 x 5/8	3
13	806006	Hairpin, cotter	2	47	1	414383	Deck weldmt (412104) w/decals, discharge baffle & support rods	1
14	811001	Zerk, straight	2	48	1	522480	Baffle, discharge	1
15	800292	Screw, 3/8-16 x 1	2	49	12	809035	Screw, 3/8-16 x1 taptite	12
16	805006	Washer, 3/8 heavy spring	2	50	1	800299	Screw, 3/8-16 x 2-3/4	1
17	373034	Washer	3	51	1	800805	Screw, 3/8-16 x 3-1/2 gr8	1
18	303514	Bearing, flange	4	52	2	633482	Blade, 18.0	2
19	804509	Nut, 1/2-13 regular	2	•	2	633484	Blade, 18.0 mulching	2
20	805008	Washer, 1/2 regular spring	2		2	633485	Blade, 18.0 low lift (optional)	2
21	522143	Fork weldmt	2	53	4	513208	Washer, spring disc	4
22	800334	Screw, 1/2-13 x 6	2	54	2	800340	Screw, 5/8-11 x 1	2
23	809007	Nut, 3/8-16 whizlock	10	55	1	603299	Roller, antiscalp	1
24	303327	Washer, 3/8 disc spring	11	56	1	603602	Bushing, roller	1
25	513648	Wheel & tire, complete	2	57	1	800807	Screw, 3/8-16 x 4 gr8	1
	513807	Wheel & hub	2	58	2	811006	Zerk, straight	2
	513808	Tire, 9 x 3.50-4 4-ply	2	59	2	804510	Nut, 5/8-18 hex	2
	513809	Roller bearing	2	60	2	413029	Pulley, w/hub	2
	513810	Bushing	2	61	4	543436	Washer	4
26	513547	Spacer	2	62	4	303543	Bearing	4
27	412238	Chute weldmt, discharge	1	63	2	303542	O-ring	2
28	413094	Belt, deck drive	1	64	2	413314	Housing, bearing	2
29	633151	Spring, extension	1	65	2	513188	Spacer, bearing	2
30	804257	Nut, 3/8-16 nylock	1	66	2	513193	Seal, mech dust	2
31	805260	Washer, 3/8 std flat	1	67	2	808506	Snap ring	2
32	513034	Bearing, pivot	2	68	2	807268	Key, machine	2
33	811008	Zerk, 90 degree	1	69	2	413035	Spindle	2
34	803016	Bolt, 3/8-16 x 1 whiz	1	70	2	414172	Cutter housing assy	2
35	805259	Washer, flat 3/8 SAE	2					

• Requires installation of Micro-Mulch accessory for proper mulching. Mulch kit P/N MK363(36")  
Exmark red touch up spray paint - P/N 850337

# 36" MOWER DECK

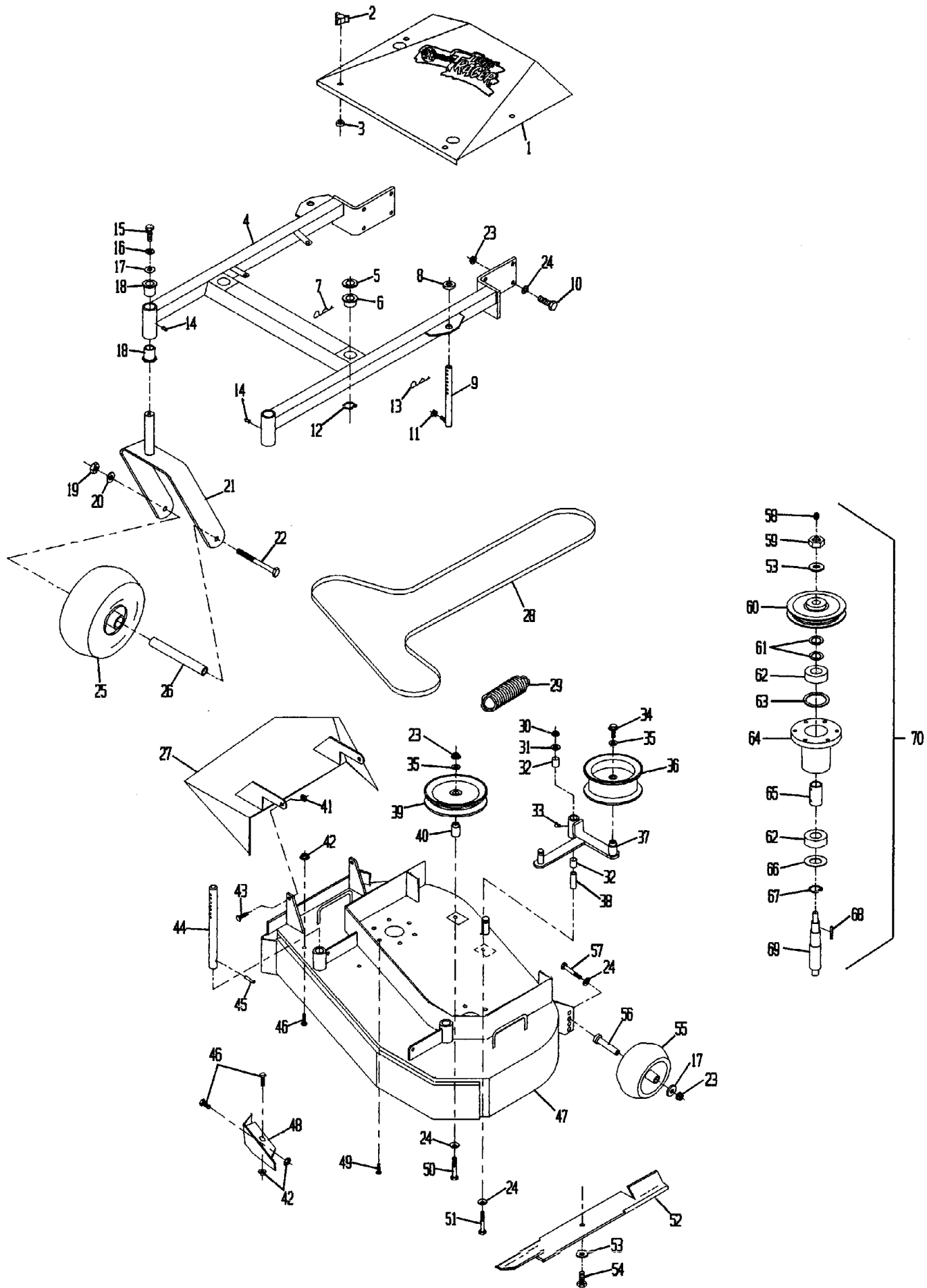

## 48" MOWER DECK

Ref. No.	Part No.	Description	Qty. Req'd.	Ref. No.	Part No.	Description	Qty. Req'd.
1	414387	Shield, belt (413101) w/decals.....	1	37	412126	Idler arm weldmt.....	1
2	323385	Knob, belt shield.....	4		414142	Idler arm weldmt w/bushings.....	1
3	323417	Washer, belt cover.....	4	38	603384	Bushing, idler pivot.....	1
4	414310	Support weldmt (412110) w/bushings, & decals.....	1	39	613098	Pulley, idler.....	2
5	513338	Washer.....	2	40	413113	Bushing, idler.....	2
6	513336	Bushing, deck support.....	2	41	804256	Nut, 5/16-18 nylock.....	8
7	806007	Hairpin, cotter.....	2	42	809001	Nut, 5/16-18 whizlock.....	5
8	303164	Spacer.....	1	43	800273	Screw, 5/16-18 x 1.....	2
9	603540	Link, rear deck support.....	2	44	603001	Rod, deck support.....	2
10	800293	Screw, 3/8-16 x 1-1/4.....	8	45	806332	Rollpin.....	2
11	803031	Nut, 3/8-24.....	2	46	800270	Screw, 5/16-18 x 5/8.....	3
12	808507	Ring, retaining.....	2	47	414384	Deck weldmt (412106) w/decals, discharge baffle & support rods.....	1
13	806006	Hairpin, cotter.....	2	48	522480	Baffle, discharge.....	1
14	811001	Zerk, straight.....	2	49	809035	Screw, 3/8-16 x1 taptite.....	18
15	800292	Screw, 3/8-16 x 1.....	2	50	800299	Screw, 3/8-16 x 2-3/4.....	2
16	805006	Washer, 3/8 heavy spring.....	2	51	800805	Screw, 3/8-16 x 3-1/2 gr8.....	1
17	373034	Washer.....	6	52	323515	Blade, 16.25.....	3
18	303514	Bearing, flange.....	4	•	403148	Blade, 16.25 mulching.....	3
19	804509	Nut, 1/2-13 regular.....	2		403149	Blade, 16.25 low lift (optional).....	3
20	805008	Washer, 1/2 regular spring.....	2	53	513208	Washer, spring disc.....	6
21	522143	Fork weldmt.....	2	54	800340	Screw, 5/8-11 x 1.....	3
22	800334	Screw, 1/2-13 x 6.....	2	55	603299	Roller, antiscalp.....	4
23	809007	Nut, 3/8-16 whizlock.....	14	56	603602	Bushing, roller.....	4
24	303327	Washer, 3/8 disc spring.....	15	57	800807	Screw, 3/8-16 x 4 gr8.....	4
25	513648	Wheel & tire, complete.....	2	58	811006	Zerk, straight.....	3
	513807	Wheel & hub.....	2	59	804510	Nut, 5/8-18 hex.....	3
	513808	Tire, 9 x 3.50-4 4-ply.....	2	60	413029	Pulley, w/hub.....	3
	513809	Roller bearing.....	2	61	543436	Washer.....	6
	513810	Bushing.....	2	62	303543	Bearing.....	6
26	513547	Spacer.....	2	63	303542	O-ring.....	3
27	522478	Chute weldmt, discharge.....	1	64	413314	Housing, bearing.....	3
28	413093	Belt, deck drive.....	1	65	513188	Spacer, bearing.....	3
29	633151	Spring, extension.....	1	66	513193	Seal, mech dust.....	3
30	804257	Nut, 3/8-16 nylock.....	1	67	808506	Snap ring.....	3
31	805260	Washer, 3/8 std flat.....	1	68	807268	Key, machine.....	3
32	513034	Bearing, pivot.....	2	69	413035	Spindle.....	3
33	811008	Zerk, 90 degree.....	1	70	414172	Cutter housing assy.....	3
34	803016	Bolt, 3/8-16 x 1 whiz.....	1	71	523471	Shield, belt.....	2
35	805259	Washer, flat 3/8 sae.....	3	72	805258	Washer, 5/16 std flat.....	6
36	413099	Pulley, idler.....	1	73	800017	Bolt, 5/16-18 x 3-1/4 tap.....	2

• Requires installation of Micro-Mulch accessory for proper mulching. Mulch kit P/N MK483(48")  
Exmark red touch up spray paint - P/N 850337

# 48" MOWER DECK

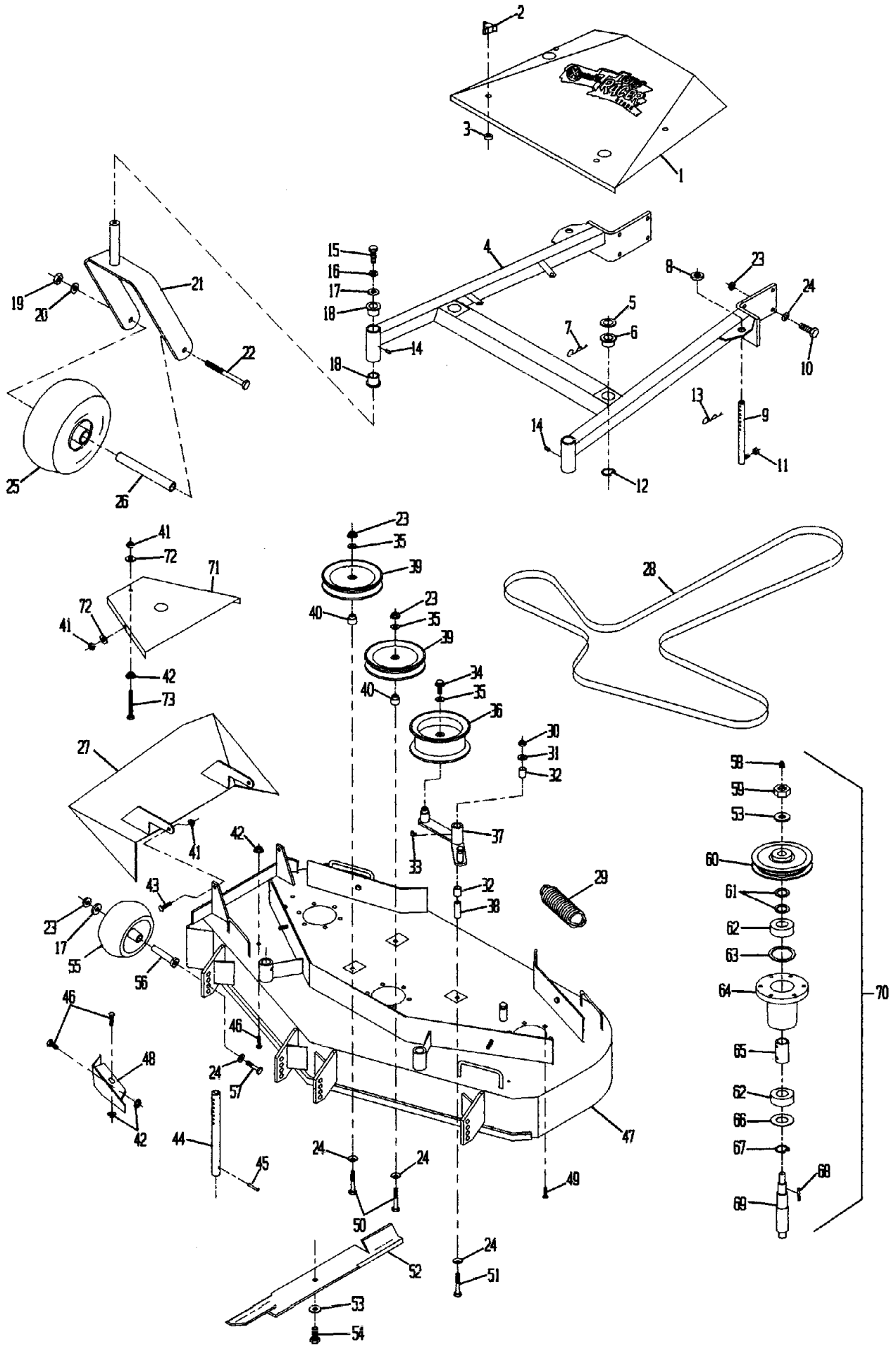

## 52" MOWER DECK

Ref. No.	Part No.	Description	Qty. Req'd.	Ref. No.	Qty. Part No.	Description	Req'd.
1	414388	Shield, belt (413303) w/decals .....	1	36	413099	Pulley, idler .....	1
2	323385	Knob, belt shield .....	5	37	412126	Idler arm weldmt .....	1
3	323417	Washer, belt cover .....	5		414142	Idler arm weldmt w/bushings .....	1
4	414311	Support weldmt (412317) w/decals		38	603384	Bushing, idler pivot .....	1
	513338	and bushings .....	1	39	613098	Pulley, idler .....	2
5	513338	Washer .....	2	40	413113	Bushing, idler .....	2
6	513336	Bushing, deck support .....	2	41	804256	Nut, 5/16-18 nylock .....	2
7	806007	Hairpin, cotter .....	2	42	809001	Nut, 5/16-18 whizlock .....	4
8	303164	Spacer .....	2	43	800273	Screw, 5/16-18 x 1 .....	2
9	603540	Link, rear deck support .....	2	44	603001	Rod, deck support .....	2
10	800293	Screw, 3/8-16 x 1-1/4 .....	8	45	806332	Rollpin .....	2
11	803031	Nut, 3/8-24 .....	2	46	800270	Screw, 5/16-18 x 5/8 .....	4
12	808507	Ring, retaining .....	2	47	414385	Deck weldmt (412313) w/decals,	
13	806006	Hairpin, cotter .....	2			discharge baffle & support rods .....	1
14	811001	Zerk, straight .....	2	48	602913	Baffle, discharge .....	1
15	800292	Screw, 3/8-16 x 1 .....	2	49	809035	Screw, 3/8-16 x1 taptite .....	18
16	805006	Washer, 3/8 heavy spring .....	2	50	800299	Screw, 3/8-16 x 2-3/4 .....	2
17	373034	Washer .....	8	51	800805	Screw, 3/8-16 x 3-1/2 gr8 .....	1
18	303514	Bearing, flange .....	4	52	633482	Blade, 18.0 .....	3
19	804509	Nut, 1/2-13 regular .....	2	•	633484	Blade, 18.0 mulching .....	3
20	805008	Washer, 1/2 regular spring .....	2		633485	Blade, 16.0 low lift (optional) .....	3
21	522143	Fork weldmt .....	2	53	513208	Washer, spring disc .....	6
22	800334	Screw, 1/2-13 x 6 .....	2	54	800340	Screw, 5/8-11 x 1 .....	3
23	809007	Nut, 3/8-16 whizlock .....	16	55	603299	Roller, antiscalp .....	6
24	303327	Washer, 3/8 disc spring .....	17	56	603602	Bushing, roller .....	6
25	513648	Wheel & tire, complete .....	2	57	800807	Screw, 3/8-16 x 4 gr8 .....	6
	513807	Wheel & hub .....	2	58	811006	Zerk, straight .....	3
	513808	Tire, 9 x 3.50-4 4-ply .....	2	59	804510	Nut, 5/8-18 hex .....	3
	513809	Roller bearing .....	2	60	413029	Pulley, w/hub .....	3
	513810	Bushing .....	2	61	543436	Washer .....	6
26	513547	Spacer .....	2	62	303543	Bearing .....	6
27	602571	Chute weldmt, discharge .....	1	63	303542	O-ring .....	3
28	413308	Belt, deck drive .....	1	64	413314	Housing, bearing .....	3
29	633151	Spring, extension .....	1	65	513188	Spacer, bearing .....	3
30	804257	Nut, 3/8-16 nylock .....	9	66	513193	Seal, mech dust .....	3
31	805260	Washer, 3/8 std flat .....	9	67	808506	Snap ring .....	3
32	513034	Bearing, pivot .....	2	68	807268	Key, machine .....	3
33	811008	Zerk, 90 degree .....	1	69	413035	Spindle .....	3
34	803016	Bolt, 3/8-16 x 1 whiz .....	1	70	414172	Cutter housing assy .....	3
35	805259	Washer, flat 3/8 sae .....	3	71	413305	Shield, belt .....	2

• Requires installation of Micro-Mulch accessory for proper mulching. Mulch kit P/N MK523(52")  
 Exmark red touch up spray paint - P/N 850337



# 52" MOWER DECK

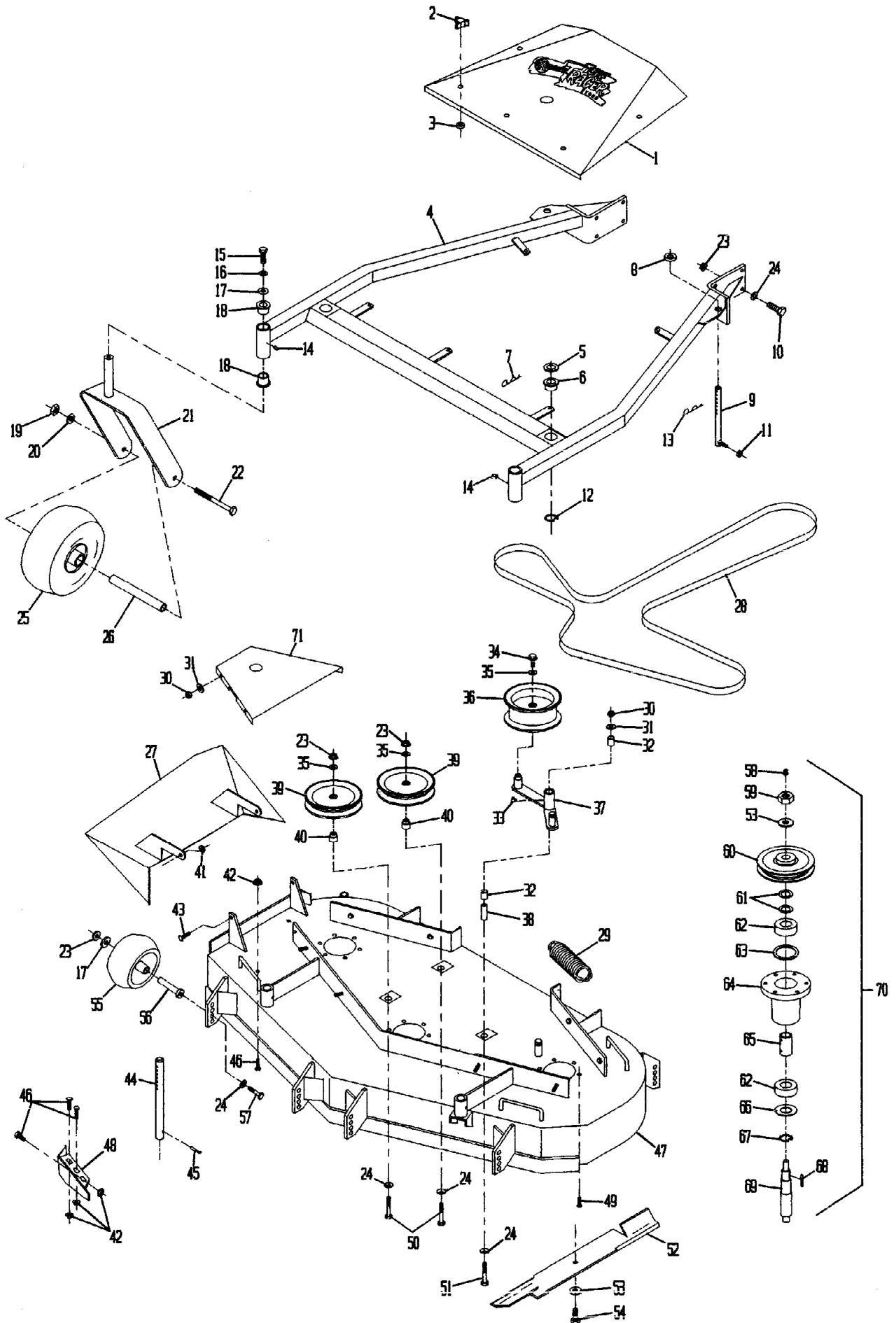

## ENGINE DECK GROUP

Ref. No.	Part No.	Description	Qty. Req'd.	Ref. No.	Part No.	Description	Qty. Req'd.
1	800297	Screw, 3/8-16 x 2-1/4.....	2	41	373034	Washer, pivot .....	2
2	303327	Washer, 3/8 disc spring .....	11	42	603610	Washer(Koh & Briggs).....	2
	303327	Washer, 3/8 disc spring(Kaw).....	12	43	809080	Screw, m10x1.5x55(Kaw) .....	1
3	603044	Bushing.....	2		800819	Scrw, 7/16-20x2-1/2(Koh&Brigs)	1
4	513034	Bearing, pivot.....	4	44	805259	Washer, 3/8 sae flat .....	1
5	811006	Zerk, straight.....	1	45	603843	Pulley, idler.....	1
6	412285	Link weldmt, pivot .....	1	46	603496	Bushing - Idler .....	1
	414143	Link weldmt, pivot w/brgs.....	1	47	603402	Spring, extension.....	1
7	800274	Screw, 5/16-18 x 1-1/4.....	1	48	412136	Idler arm weldmt.....	1
8	800254	Screw, 1/4-20 x 1.....	2		414141	Idler arm weldmt w/brgs .....	1
9	809012	Nut, 1/4-20 whizlock .....	4	49	811007	Zerk, 45 degree .....	2
10	523498	Spring, motion control.....	1	50	800299	Screw, 3/8-16 x 2-3/4 .....	1
11	513113	Spring, belt tension .....	1	51	800295	Screw, 3/8-16 x 1-3/4 .....	2
12	543007	Spacer .....	1	52	809069	Screw, #10-24 x 7/8 .....	1
13	213069	Washer .....	2	53	323365	Chain, cold start .....	1
14	804256	Nut, 5/16-18 nylock.....	1	54	805252	Washer, 7/32 std flat .....	1
15	805260	Washer, 3/8 std flat.....	2	55	804252	Nut, #10-24 nylock .....	1
16	809007	Nut, 3/8-16 whizlock .....	19	56	807272	Key, 5mm sq x 25mm.....	2
17	413282	Linkage .....	1	57▽	803050	Setscrew, sq hd cuppoint.....	4
18	806003	Hairpin cotter .....	1	58	413095	Belt, pump drive.....	1
19	412132	Deck weldmt, engine .....	1	59	413010	Sheave, pump drive .....	2
20	800290	Screw, 3/8-16 x 3/4.....	2	60	413096	Belt, blade clutch .....	1
21	633068	Arm .....	1	61	807259	Key, 1/4 sq x 1.....	2
22	809001	Nut, 5/16-18 whizlock .....	7	62◇	412011	Sheave w/shaft.....	1
	809001	Nut, 5/16-18 whizlock(Briggs).....	11	63◇	413111	Bearing, clutch.....	2
23	303334	Washer, 5/16 disc spring .....	5	64	808502	Ring, retaining .....	2
24	322110	Guide weldmt, belt.....	1	65	413012	Spacer, bearing .....	1
25	809072	Screw, m8x1.25x25(Kaw&Koh).....	3	66	523157	Washer, spacer .....	1
	800275	Screw, 5/16-18 x 1-1/2(Briggs).....	3	67	413049	Plate, clutch pivot .....	1
26	809018	Screw, m8x1.25x30(Kaw&Koh).....	1	68	800273	Screw, 5/16-18 x 1 .....	6
	800276	Screw, 5/16-18 x 1-3/4(Briggs).....	1	69	413207	Pivot, bearing.....	2
27	800303	Screw, 3/8-16 x 4-1/2.....	1	70	412290	Arm weldmt, clutch .....	1
28	323366	Ring, split.....	1		414145	Arm weldmt, clutch w/brgs .....	1
29	804257	Nut, 3/8-16 nylock.....	6	71	413235	Washer, spacer .....	1
30	800292	Screw, 3/8-16 x 1.....	8	72	412138	Pin weldmt, pivot .....	1
31	412080	Mount, wheel motor 36".....	2	73	800271	Screw, 5/16-18 x 3/4 .....	1
	412082	Mount, wheel motor 48" & 52".....	2	74	413062	Band, brake .....	1
32	803045	Screw, 3/8-16 x 3/4 whizlock .....	8	75	800294	Screw, 3/8-16 x 1 1/2 .....	2
33◇	602997	Hub, four bolt w/studs .....	2	76	412325	Guide weldmt, belt.....	1
	613150	Stud .....	8	77◇	412031	Sheave w/drum (36" & 52") .....	1
34	603714	Wheel & tire assy.....	2		412028	Sheave w/drum (48").....	1
	603427	Tire 16 x 6.50-8.....	2	78	800521	Screw, 3/8-24 x 1 .....	1
	603715	Wheel.....	2	79	413009	Plate, guard .....	1
35	513011	Nut, wheel 1/4-20.....	8	80	805258	Washer, 5/16 std flat .....	2
36	803040	Nut, slotted 3/4-16 .....	2	81◆	403124	Elbow (Briggs).....	1
37	806800	Pin, cotter 9/64 x 1-1/2.....	2	82◆	543232	Nipple, pipe (Briggs).....	1
38	807264	Key, 1/4sq x 2-5/8.....	1	83◆	543233	Cap (Koh & Briggs) .....	1
39◇	413004	Sheave assy, drive .....	1	84◆	303431	Elbow (Koh & Briggs) .....	1
40	603609	Bushing.....	1	85◆	323326	Nipple, pipe (Koh).....	1

▽ Use Pro-Lock (nut type, Part no. 840022, 5 ml tube) on setscrew threads.

◆ Use a Teflon pipe sealant of equivalent on threads.

Exmark red touch up spray paint - P/N 850337

◇ Apply antiseize to shaft on sheave, drive sheave bore and wheel hub bore.

# ENGINE DECK GROUP

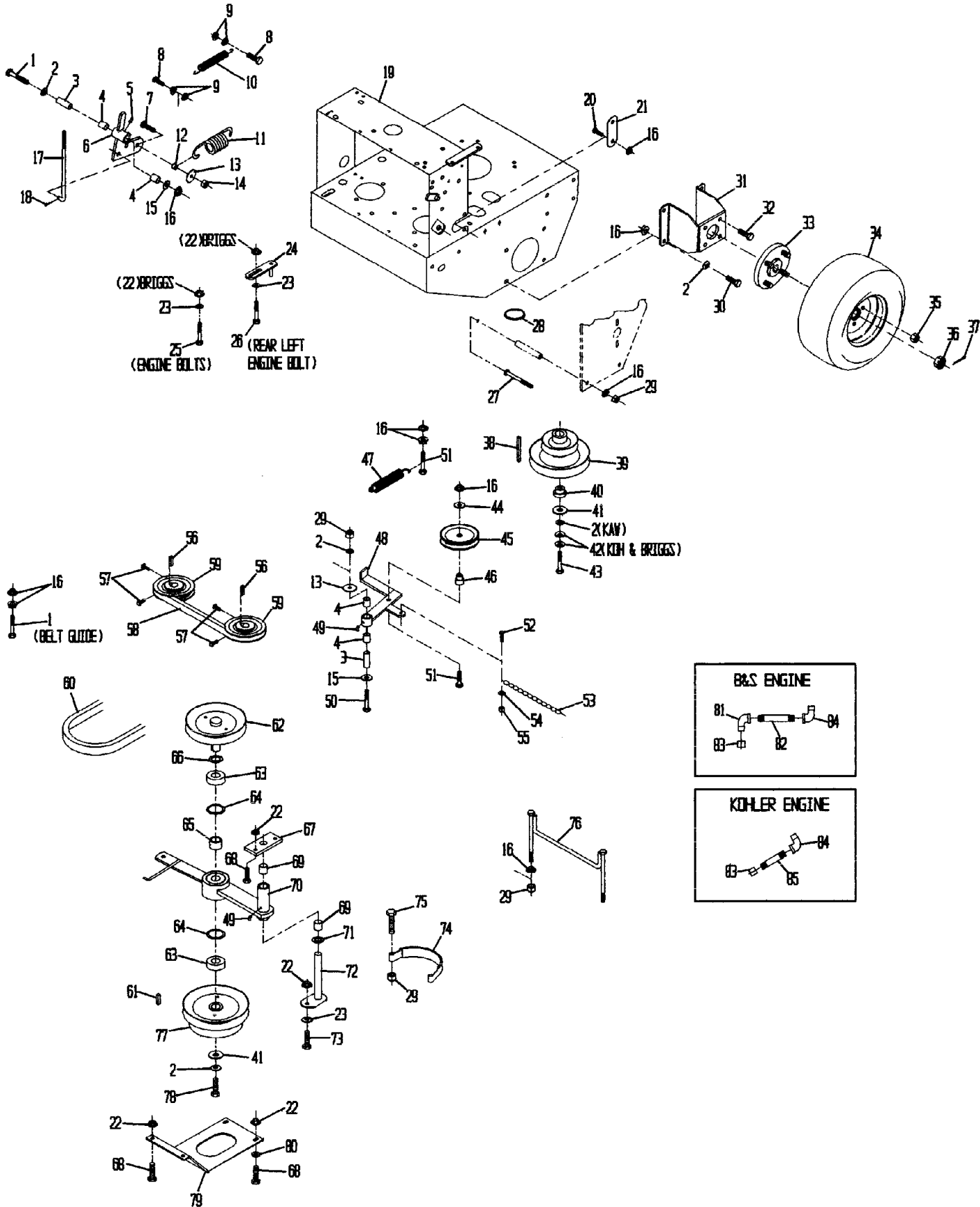

## ENGINE DECK GROUP (con't.)

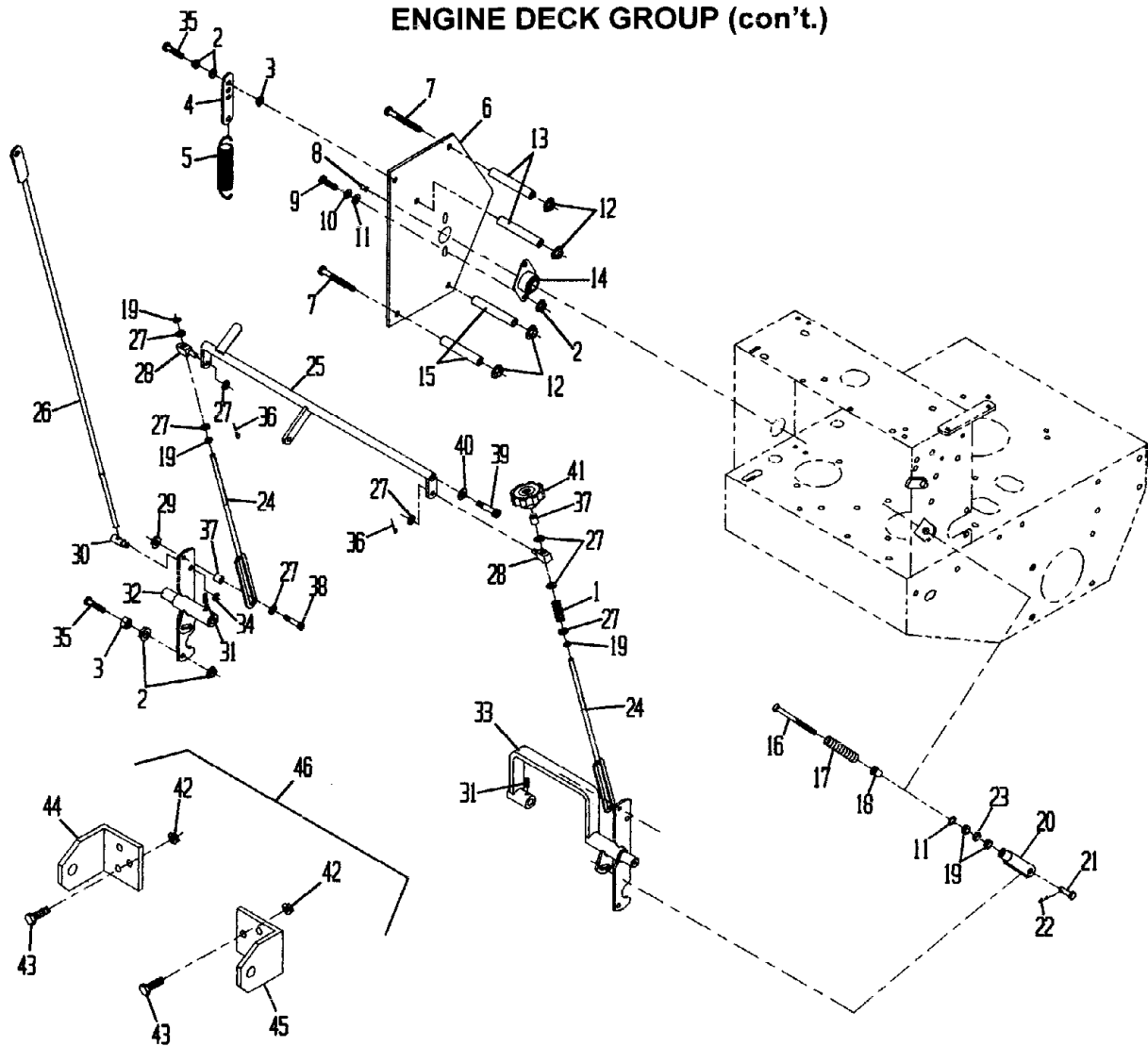

Ref. No.	Part No.	Description	Qty. Req'd.	Ref. No.	Part No.	Description	Qty. Req'd.
1	323245	Spring .....	1	24	412276	Rod, control .....	2
2	809001	Nut, 5/16-18 whizlock .....	12	25	412203	Crank weldmt .....	1
3	804256	Nut, 5/16-18 nylock .....	4	26	413219	Rod, drive lever .....	2
4	613089	Tab, spring extension .....	2	27	805257	Washer, 5/16 SAE .....	9
5	603693	Spring, extension .....	2	28	603676	Swivel, short .....	2
6	413201	Shield, hydro .....	2	29	809012	Nut, 1/4-20 whizlock .....	2
7	800302	Screw, 3/8-16 x 4 .....	7	30	413227	Swivel, drive lever .....	2
8	811006	Zerk, 1/4-28 .....	2	31♦	803022	Setscrew, 5/16-18x5/8 .....	2
9	800271	Screw, 5/16-18 x 3/4 .....	4	32	412272	Arm weldmt, LH .....	1
10	805005	Washer, 5/16 hvy spr lock .....	4	33	412270	Arm weldmt, RH .....	1
11	805256	Washer, 1/4 std flat .....	6	34	808520	Klipring .....	2
12	809007	Nut, 3/8-16 whizlock .....	8	35	800274	Screw, 5/16-18 x 1-1/4 .....	4
13	323195	Spacer, shield .....	4	36	806753	Cotter pin, 3/32 x 1/2 .....	2
14	633102	Bearing, side flange .....	2	37	603903	Spacer .....	3
15	323197	Spacer, shield .....	4	38♦	809057	Bolt, .312 x .75 hx skt hd shldr 2	
16	603737	Bolt, neutral return .....	2	39♦	809056	Bolt, .375 x .375 hx skt hd shldr 2	
17	603807	Spring, neutral return .....	2	40	805259	Washer, 3/8 SAE flat .....	2
18	603735	Bushing, nylon .....	2	41	413151	Knob .....	1
19	804521	Nut, 5/16-24 hex .....	7	42	809007	Nut, 3/8-16 whizlock .....	6
20	303105	Yoke .....	2	43	800292	Screw, 3/8-16 x 1 .....	6
21	808280	Clevis pin, 5/16 x 1 .....	2	44	413252	Bracket, sulky LH .....	1
22	806003	Hairpin cotter .....	2	45	413254	Bracket, sulky RH .....	1
23	804758	Nut, 5/16-24 jam .....	2	46	411255	Sulky kit .....	1

♦Use Pro-Lock nut type, Part No. 840022 (.5 ml tube) on bolt & setscrew threads.

Exmark red touch up spray paint - PN 850337

# HYDRAULICS GROUP

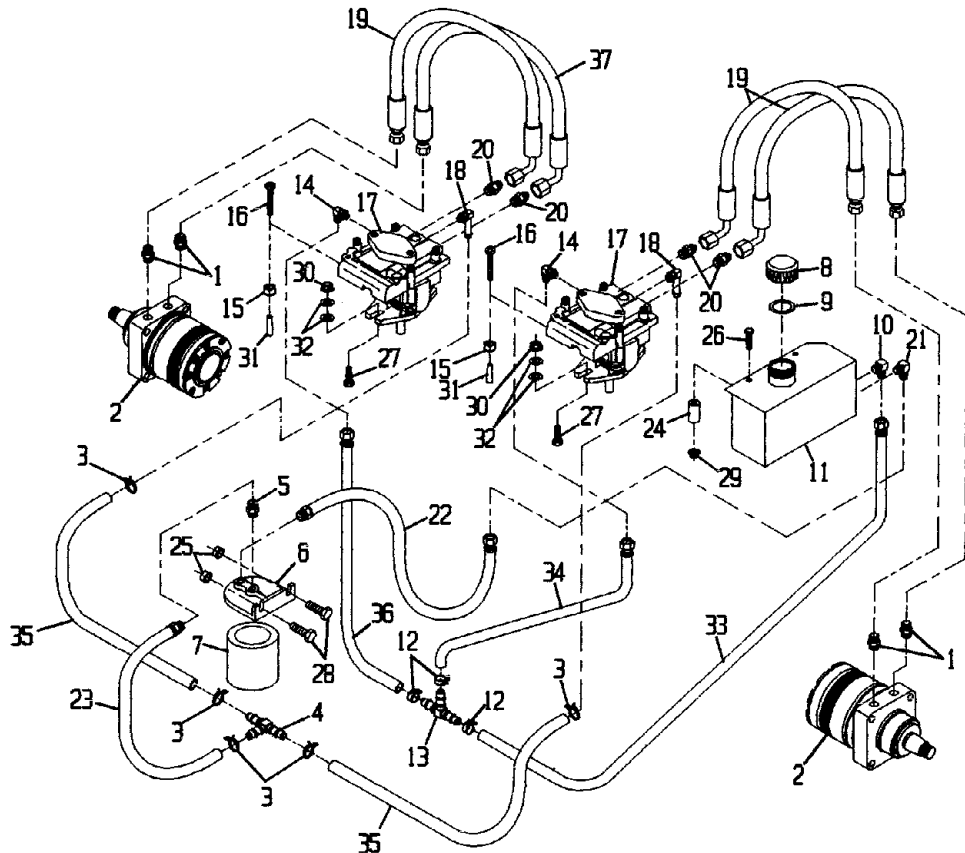

Ref. No.	Part No.	Description	Qty. Req'd.	Ref. No.	Part No.	Description	Qty. Req'd.
1	603991	Fitting, strght connector.....	4	18	603989	Elbow, 90°.....	2
	603919	Boss O-Ring.....	1		603923	O-Ring.....	1
	603992	Flare O-Ring.....	1	19	613034	Hose, high pressure.....	3
2	603718	Wheel motor.....	2	20	603990	Adapter, straight thread.....	4
	000138	Kit, Bearing.....	1		603920	Boss O-Ring.....	1
	000119	Kit, seal.....	1		603992	Flare O-Ring.....	1
3	603827	Clamp, hose (5/8).....	5	21	603988	Elbow, 90°.....	1
4	603721	Fitting, Hose Tee (3/8 I.D hose).....	1	22	602985	Hose, supply.....	1
5	513510	Connector, male.....	1	23	602754	Hose, charge line.....	1
6*	603720	Head, filter.....	1	24	323218	Spacer, hydraulic tank.....	2
7	513211	Element, oil filter.....	1	25	809001	Nut, whizlock 5/16-18.....	2
∇	523541	Element, oil filter(winter).....	1	26	800258	Screw, 1/4-20 x 2.....	2
8	513167	Cap, hydraulic reservoir.....	1	27	800293	Screw, 3/8-16 x 1-1/4.....	4
9	523103	Gasket, tank cap.....	1	28	800273	Screw, 5/16-18 x 1.....	2
10	603987	Elbow, 90°.....	1	29	809012	Nut, whizlock 1/4-20.....	2
11*	512166	Reservoir, hydraulic fluid.....	1	30	809007	Nut, whizlock 3/8-16.....	4
12	603826	Hose Clamp 1/2.....	3	31	613073	Grip, dump valve.....	2
13	603722	Fitting - Hose Tee(1/4 I.D hose).....	1	32	805258	Washer, 5/16 std.....	8
14	513840	Elbow - 90°.....	2	33	602750	Hose, case drain.....	1
	603921	O-Ring.....	1	34	632286	Hose assy, lo pressure.....	1
15	804255	Nut, nylock 1/4-20.....	2	35	413273	Hose, lo pressure.....	2
16	801063	Screw, 1/4-20 x 2 pan head ...	2	36	632285	Hose assy, lo pressure.....	1
17	613042	Pump, hydro.....	2	37	323241	Hose, high pressure.....	1

\* Use Teflon Pipe Sealant or equivalent on hydraulic reservoir and filter head fittings.

∇ Use only for operation below 32°F(0°C)

Emark black touch up spray paint - gloss black

