

M216KASPC

For Serial Nos.  
440,000 & Higher



PARTS MANUAL

# METRO<sup>®</sup> 21

**CONGRATULATIONS** on the purchase of your new Exmark mower. This product has been carefully designed and manufactured to give you a maximum amount of dependability and years of trouble-free operation. If additional information is needed, or should you require trained mechanic service, contact your authorized Exmark equipment dealer or distributor. If you need to order replacement parts from your dealer, always give the model number and serial number of your mower as well as the part number, description and quantity of the part needed.

The Serial No. plate is located on the top of the mower deck on the right hand corner of the machine. For ease of ordering and reference, we suggest that you record the information requested in the following identification table.

Place Model No. and Serial No. Label Here  
(Included in Literature Pack)  
or Fill in Below

Model No. \_\_\_\_\_

Serial No. \_\_\_\_\_

Engine Model No. and Spec. No. (Code) \_\_\_\_\_

Engine Serial No. (E/No) \_\_\_\_\_

Date Purchased \_\_\_\_\_

# EXMARK PARTS PLUS® PROGRAM

EFFECTIVE DATE: September 1, 1995

## Program

If your Exmark dealer does not have the Exmark part in stock, Exmark will get the parts to the dealer the next business day or the part will be FREE\* Guaranteed!!

## *How the Program Works*

1. If dealer does not have part in stock for a "down" unit at the time of request by customer, the dealer contacts his distributor by 1:00 p.m., local time, and requests Exmark Parts Plus® shipment of six (6) line items or less.
2. Distributor ships part(s) to dealer or customer, as requested by dealer, same day, overnight UPS. Distributor bills dealer for part and freight charges where applicable.
3. If distributor does not have the part(s) in stock to satisfy Exmark Parts Plus® order, he contacts Exmark by 3:00 p.m., central time, with an Exmark Parts Plus® order of six (6) line items or less.
4. If order is received by 3:00 p.m. central time, Exmark ships part(s) direct to dealer or customer, as requested by distributor, same day, overnight UPS, Exmark bills the distributor for parts and shipping charges, where applicable.
5. The customer pays for the part and freight if it is shipped under the Exmark Parts Plus® and if it arrives in accordance to the program.
6. Who pays for the part and freight if it fails to arrive overnight in accordance to the program?
  - A. Under any circumstance the customer does not pay.
  - B. If the part does not arrive overnight due to:
    1. The dealer not submitting the Exmark Parts Plus® order to his Exmark distributor by 1:00 p.m., the dealer pays for the part and freight.
    2. The Distributor being unable to ship the part the same day or not submitting the Exmark Parts Plus® order to Exmark by 3:00 p.m., central time, the Distributor pays for the part and freight.
    3. Exmark being unable to ship the part and the Exmark parts order is received by 3:00 p.m., central time, Exmark pays for the part and freight.
    4. If the part does not arrive overnight due to the shipper (UPS), the shipper pays for the freight and Exmark pays for the part.

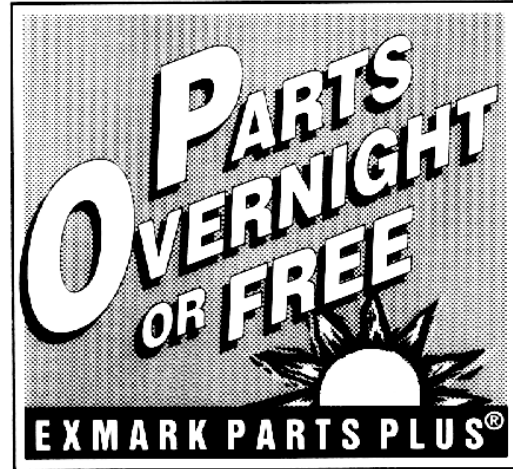

**The following restrictions apply** -- The Exmark Parts Plus® Program is available only through participating Exmark Dealers and applies only to orders submitted on this program Monday through Thursday. Parts Plus service is available only in the 48 contiguous United States. UPS has initiated a Saturday delivery program to many areas of the continental United States and can be requested for an overnight shipment on Friday to be delivered Saturday. The next day air charge, plus the Saturday delivery fee will be the responsibility of the purchaser. Exmark Mfg. will assume no responsibility for Saturday delivery shipments. To qualify, all Exmark Parts Plus® orders must be received by Exmark by 3:00 p.m., central time. Orders must be six (6) line items or less. Exclusions from the Exmark Parts Plus® Program are: Any wholegood or accessory in its entirety, engines and engine replacement parts, 5-speed Peerless transmissions and 5-speed transaxles, hydraulic or hydrostatic wheel motors, cutter decks and engine decks or any item exceeding United Parcel Service size and weight restrictions.

Due to UPS restrictions, aerosol spray paint is considered a hazardous material and cannot be shipped via UPS next day or Second Day Air.

Exmark Manufacturing stocks a limited supply of parts for transaxles, pumps and wheel motors. These parts can be ordered for Next Day Air shipment but will not be guaranteed per the Parts Plus Program



## READ OPERATOR'S MANUAL BEFORE OPERATING OR SERVICING EXMARK EQUIPMENT.

### Contents

Description	Page	Description	Page
Housing Assembly	..... 4	Rear Wheel Assembly	..... 13
Front Wheel and Tire Assembly	..... 6	Grass Bag Assembly No. 100-2886	..... 14
Gear Case Assembly No. 74-1861	..... 7		
Engine and Blade Assembly	..... 8		
Fuel Line and Tank Assembly	..... 9		
Handle Assembly	..... 10		
Control Assembly	..... 11		
Rear Axle and Transmission Assembly	..... 12		

### Part Description Abbreviations

Part descriptions in this catalog may include the following abbreviations.

AR. .... as required	HYD. .... hydraulic
ASM. .... assembly	INC. .... incorporated
CARR. .... carriage	LH. .... left hand
DEG. .... degrees	NI. .... nylon insert
FH. .... flat head	PPH. .... phillips pan head
GA. .... gauge	PTH. .... phillips truss head
HF. .... hex flange	PTO. .... power take off
HH. .... hex head	RH. .... right hand
HHF. .... hex head flange	SFH. .... slotted fillister head
HHFTF. .... hex head flange thread forming	SHH. .... slotted hex head
HJ. .... hex jam	SHWH. .... slotted hex washer head
HLH. .... hex lag head	SPH. .... slotted pan head
HOC. .... height-of-cut	SQH. .... square head
HS. .... hex	SRH. .... slotted round head
HSBH. .... hex socket button head	STD. .... standard
HSFH. .... hex socket flat head	TAP. .... self tapping
HSH. .... hex socket head	TTH. .... torx truss head
HWH. .... hex washer head	WH. .... wing head
HWHTF. .... hex washer head thread forming	

### Footnotes

❶ Not illustrated

❷ Not serviced separately

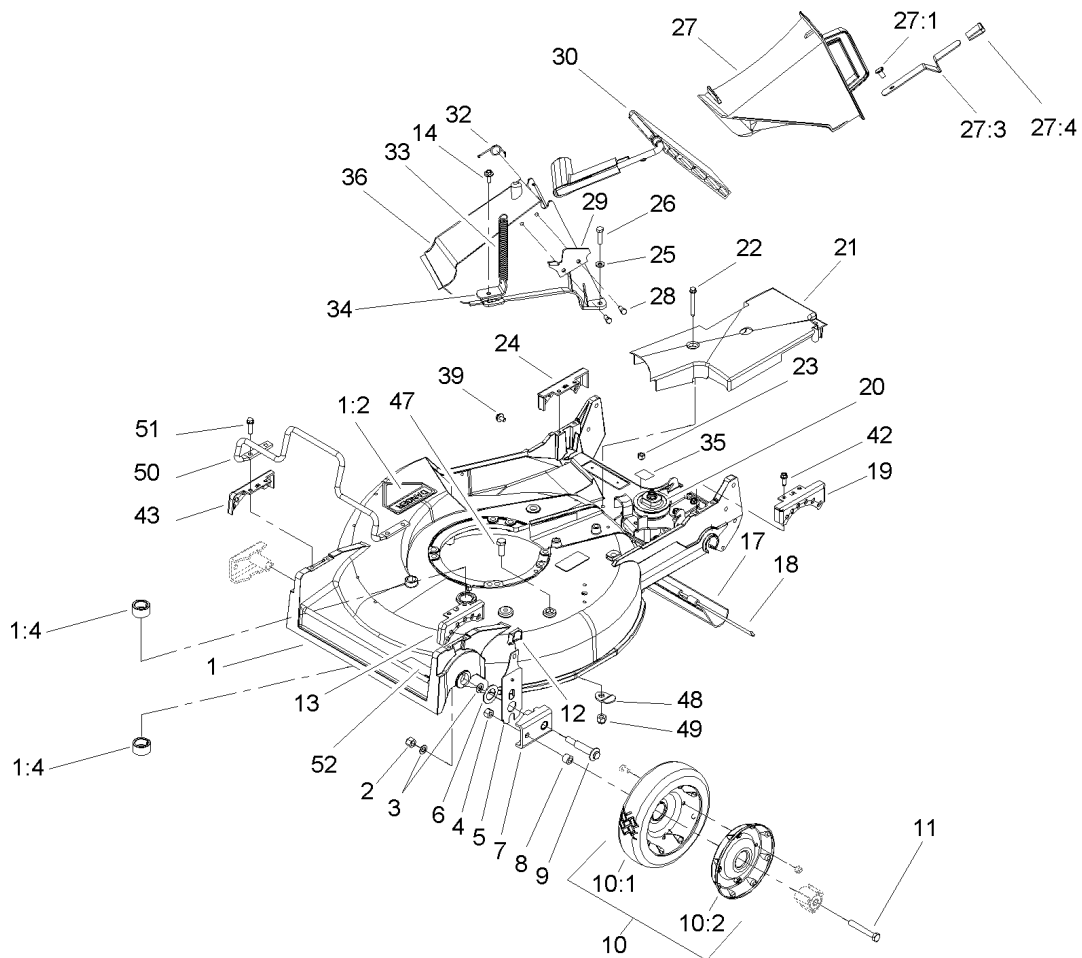

## Housing Assembly

Ref	Part No.	Qty.	Description	Ref	Part No.	Qty.	Description
1	100-3288	1	Housing ASM	23	3296-42	2	Nut-Lock, NI
1:2	43-8480	1	Decal-Danger	24	49-8750	1	Quadrant-Rear, RH
1:4	68-9780	2	Bearing	25	3256-22	2	Washer-Flat
2	3296-6	2	Nut-Lock, NI	26	321-7	2	Screw-HH
3	40-1940	4	Washer	27	77-0500	1	Discharge Plug ASM
4	32152-2	2	Nut-Hex	27:1	3295-35	1	Rivet-Head, Flat
5	66-7560	2	Front Spring Arm ASM	27:3	76-4640	1	Latch-Plug, Discharge
6	257-3	2	Washer-Thrust	27:4	76-4650	1	Grip-Latch
7	61-8300	2	Arm-Pivot, Front	28	46-8090	2	Screw-Plastite
8	52-2480	2	Spacer-Wheel	29	93-3154	1	Latch-Plate
9	27-6232	2	Bolt-Wheel	30	93-7351	1	Discharge Door ASM
10	100-2870	2	Wheel And Tire ASM	32	80-3770	1	Retainer-Door
10:1	53-7740	1	Tire	33	76-4660	1	Spring-Door
10:2		1	Wheel ASM	34	71-9350	1	Bracket-Spring
11	323-12	2	Screw-HH	35	52-2620	1	Label-Grease
12	25-7740	2	Knob-Arm	36	82-9152	1	Tunnel-Discharge
13	49-8760	1	Quadrant-Front, LH	39	46-6810	1	Screw And Washer ASM
14	46-6811	1	Screw-HWH	42	49-2040	4	Screw-Tapping
17	44-0580	1	Shield-Trailing	43	49-8770	1	Quadrant-Front, RH
18	33-3208	1	Rod-Shield	47	323-6	3	Screw-HH
19	49-8740	1	Quadrant-Rear, LH	48	84-8930	3	Shield-Retainer
20	74-1861	1	Gear Case ASM	49	3296-39	3	Nut-Lock, NI
21	74-1770	1	Cover-Belt	50	99-6722	1	Guard-Engine
22	37-7260	2	Screw-HH	51	32144-86	4	Screw-Hwh, Thread Forming

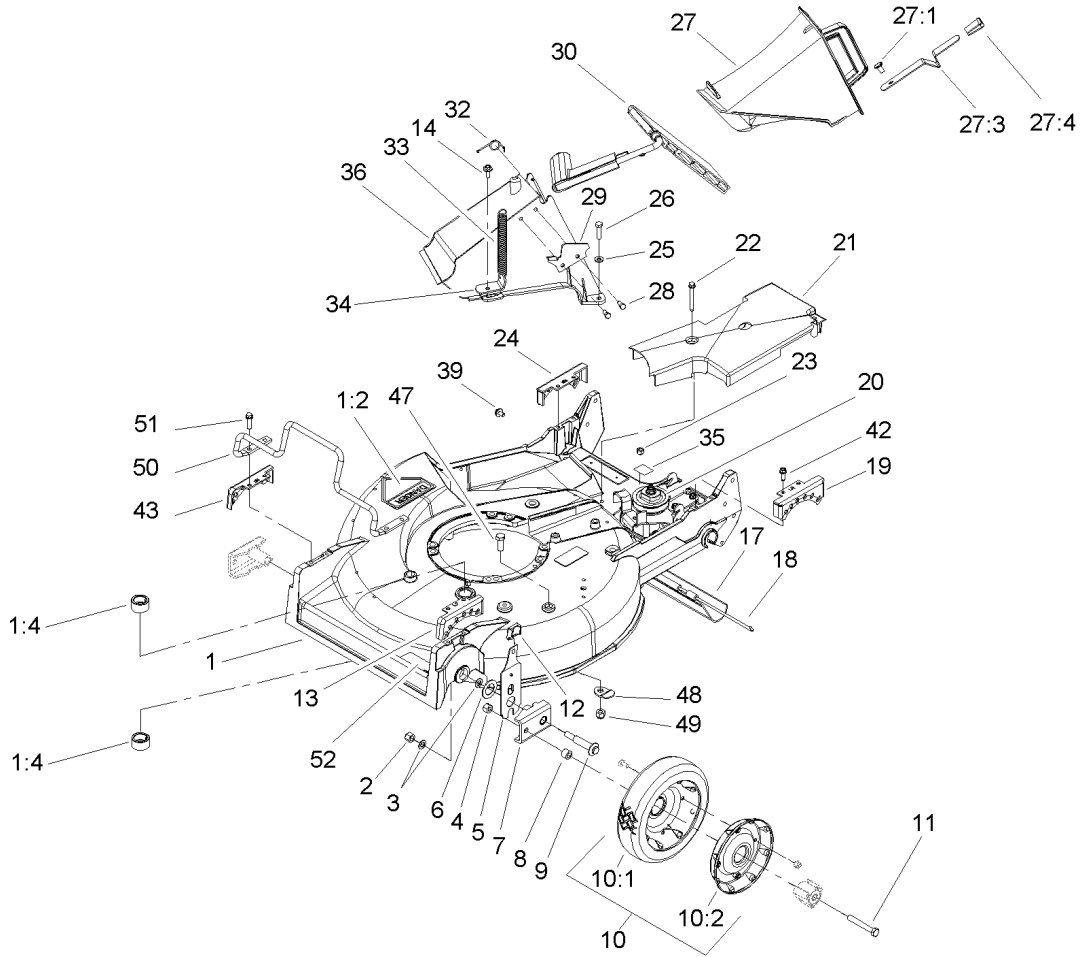

### Housing Assembly (continued)

Ref	Part No.	Qty.	Description				
52	68-7410	1	Decal-Blade				

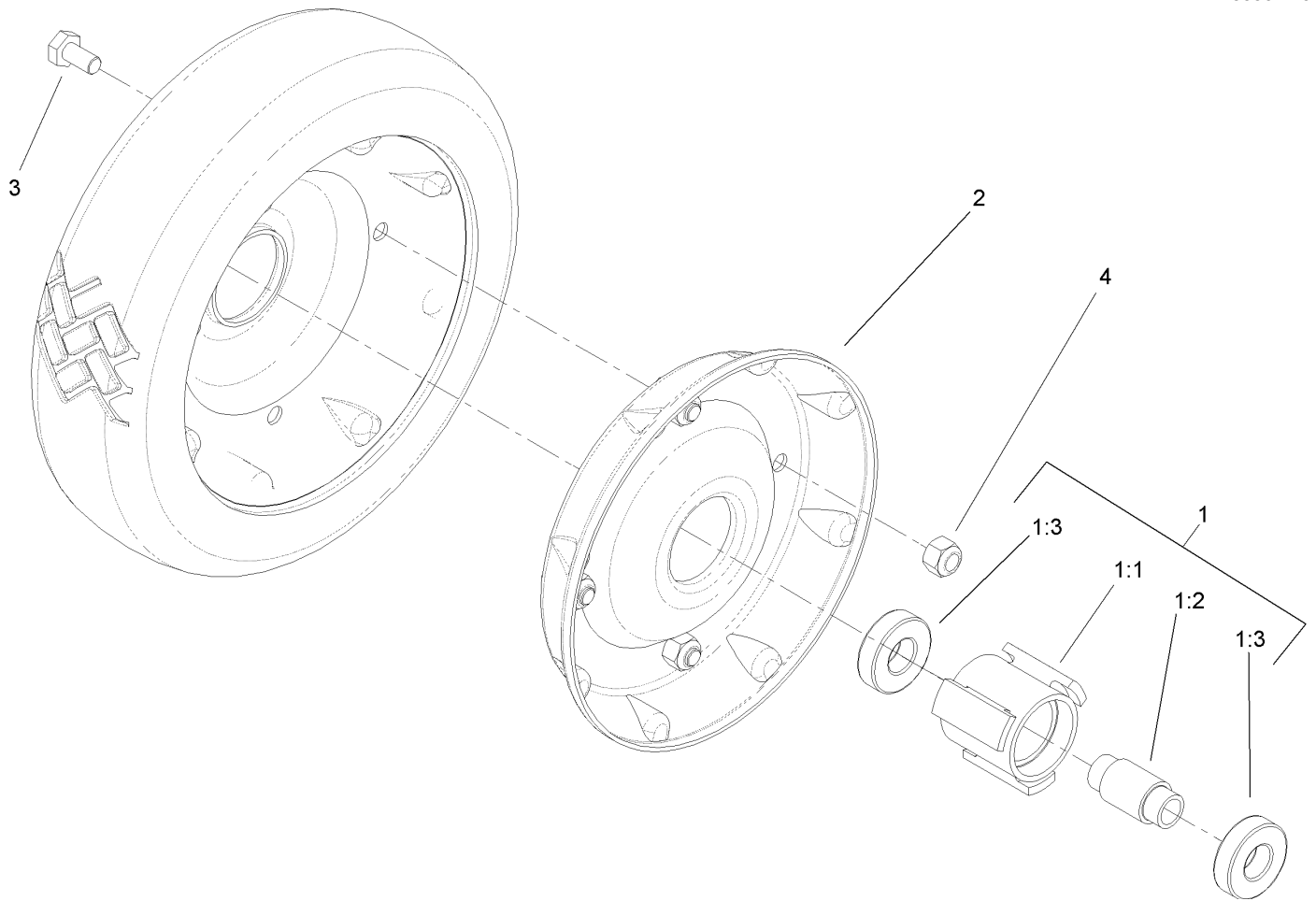

## Front Wheel and Tire Assembly

Ref	Part No.	Qty.	Description
1		1	Hub And Bearing ASM
1:1	52-2410	1	Hub-Bearing
1:2	52-2440	1	Spacer-Bearing
1:3	52-2450	2	Bearing-Wheel
2	53-7780-06	2	Plate-Wheel, Half
3	321-2	4	Screw-HH
4	3296-42	4	Nut-Lock, NI

--	--	--	--

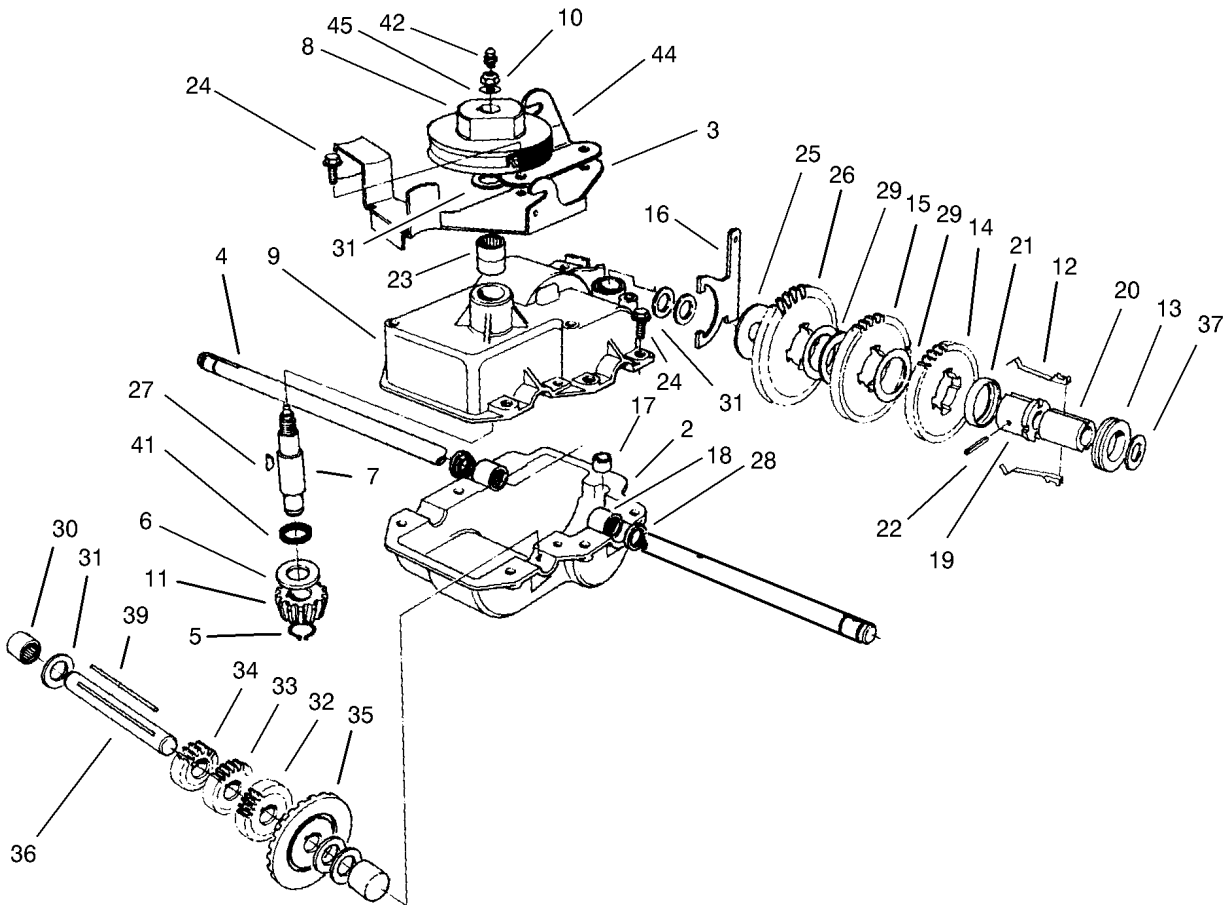

### Gear Case Assembly No. 74-1861

Ref	Part No.	Qty.	Description
2	74-1920	1	Case-Gear, Lower
3	49-8461-03	1	Bracket-Guide, Belt
4	74-1890	1	Shaft-Output
5	32151-57	1	Ring-Retaining
6	47-2910	1	Washer-Thrust
7	68-8190	1	Shaft-Input
8	39-6740	1	Pulley
9	74-1880	1	Case-Gear, Upper
10	3296-5	1	Nut-Lock, NI
11	39-6660	1	Pinion-Bevel
12	29-9330	2	Key-Shift
13	29-9340	1	Collar-Shift
14	42-4740	1	Gear-38 Tooth
15	29-9271	1	Gear-42 Tooth
16	60-8870	1	Yoke-Shift
17	29-9570	1	Bushing-Yoke
18	47-6730	2	Seal-Oil
19	55-8010	1	Sleeve-Gear
20	39-6720	1	Sleeve
21	55-8020	1	Retainer-Key
22	3285-19	1	Pin-Groove
23	47-7270	2	Bearing
24	49-2040	6	Screw-Tapping
25	29-9690	1	Washer

Ref	Part No.	Qty.	Description
26	46-3560	1	Gear
27	3257-1	2	Key-Woodruff
28	48-2060	2	Bearing-Roller
29	36-4770	3	Washer
30	252-103	2	Bearing-Closed
31	36-4792	4	Washer-Thrust
32	39-6650	1	Gear-18t
33	46-3550	1	Gear-14t
34	46-3540	1	Gear-12t
35	74-1760	1	Gear-Bevel
36	53-7950	1	Shaft-Intermediate
37	36-4780	3	Washer
39	39-7842	1	Key
41	47-7260	1	Seal
42	302-63	1	Zerk
44	74-1750-03	1	Brake-Engage, Traction
45	3256-45	1	Washer-Flat

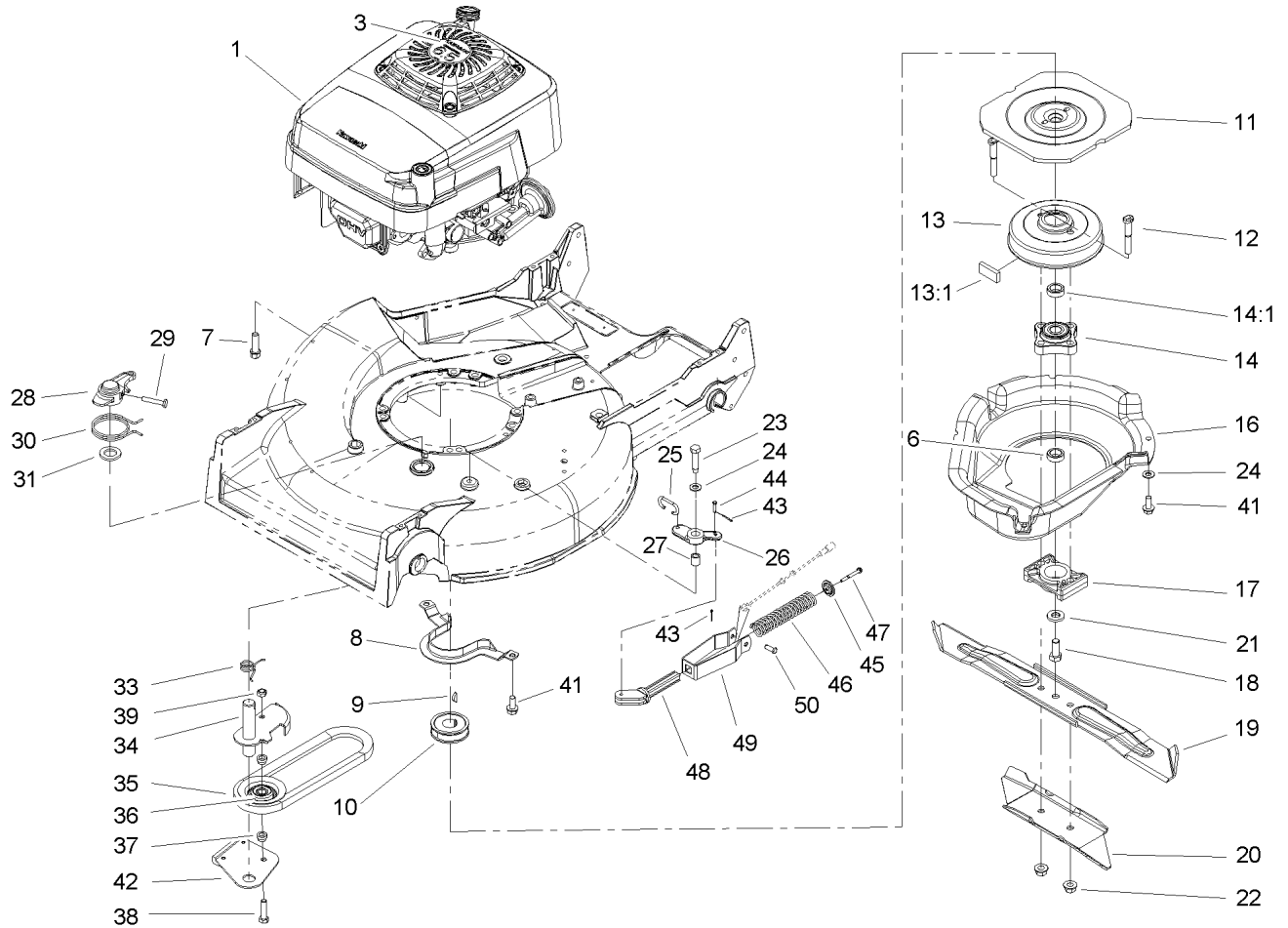

## Engine and Blade Assembly

Ref	Part No.	Qty.	Description
1		1	Engine-Kawasaki, Fj180v-As09
3	106-0843	1	Decal-Recoil
6	107-4058	1	Spacer-Output Shaft
7	95-1727	4	Screw-Taptite
8	66-0570-03	1	Bracket-Guide, Belt
9	3257-17	1	Key-Woodruff
10	56-6180	1	Pulley-Driver
11	56-6160-03	1	Flywheel-Bbc
12	42-3190	2	Bolt-Blade
13	94-9431	1	Brake Drum ASM
13:1	52-3480	2	Dampner-Vibration
14	42-6890	1	Hub ASM
14:1	100-1048	2	Bearing-Ball
16	46-5693	1	Shield
17	62-4280	1	Spacer-Blade
18	3212-4	1	Screw-HH
19	42-1000-03	1	Blade
20	91-2255-03	1	Stiffener-Blade
21	107-4059	1	Cap-Engine
22	54-9190	2	Nut-Lock
23	32104-107	1	Screw-HH
24	3256-23	2	Washer-Flat
25	49-2810	1	Link-Control
26	49-7960	1	Bellcrank

Ref	Part No.	Qty.	Description
27	49-7950	1	Sleeve-Bellcrank
28	49-2820	1	Lever
29	32104-96	1	Screw-HH
30	49-7970	1	Spring-Torsion
31	70-1160	1	Washer
33	85-6880	1	Spring-Torsion
34	84-9130	1	Arm-Idler
35	100-6486	1	V-Belt
36	46-5650	1	Pulley-Idler
37	46-5631	2	Hub-Pulley, Idler
38	322-6	1	Screw-HH
39	3296-47	1	Nut-Lock, NI
41	32144-70	3	Screw-HH
42	84-9180	1	Brake Plate ASM
43	3272-1	2	Pin-Cotter
44	84-9050	1	Pin-Spring
45	65-5280	1	Retainer-Spring
46	84-9100	1	Spring
47	46-7040	1	Screw-HWHTF
48	84-8870	1	Guide-Spring
49	84-8880-03	1	Bracket-Spring
50	84-9040	1	Pin-Cable



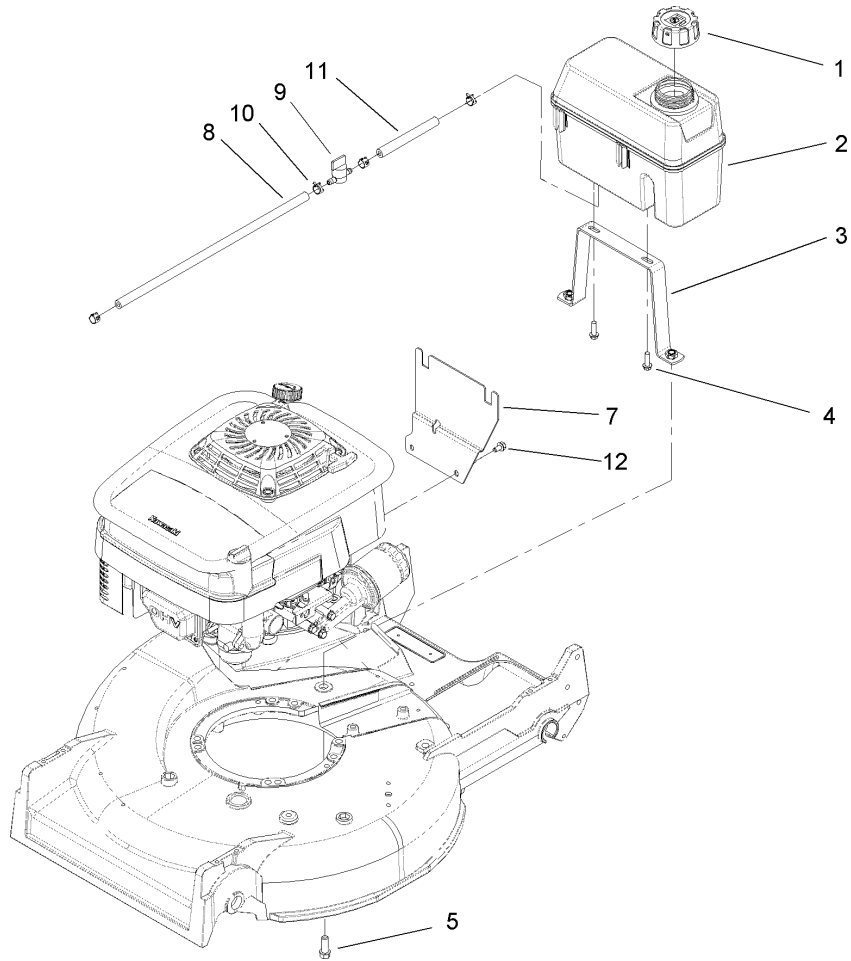

## Fuel Line and Tank Assembly

Ref	Part No.	Qty.	Description
1	93-7198	1	Gas Cap ASM
2	106-0625	1	Tank-Fuel
3	84-9160-03	1	Base-Tank
4	46-8091	2	Screw-HWH
5	95-1726	2	Screw-Taptite
7	106-0908-03	1	Bracket-Tank
8	47-2983	1	Hose-Fuel
9	1-603770	1	Valve-Fuel
10	2412-98	4	Clamp
11	106-0999	1	Hose-Gas
12	104-2628	3	Screw-HWH

--	--	--	--

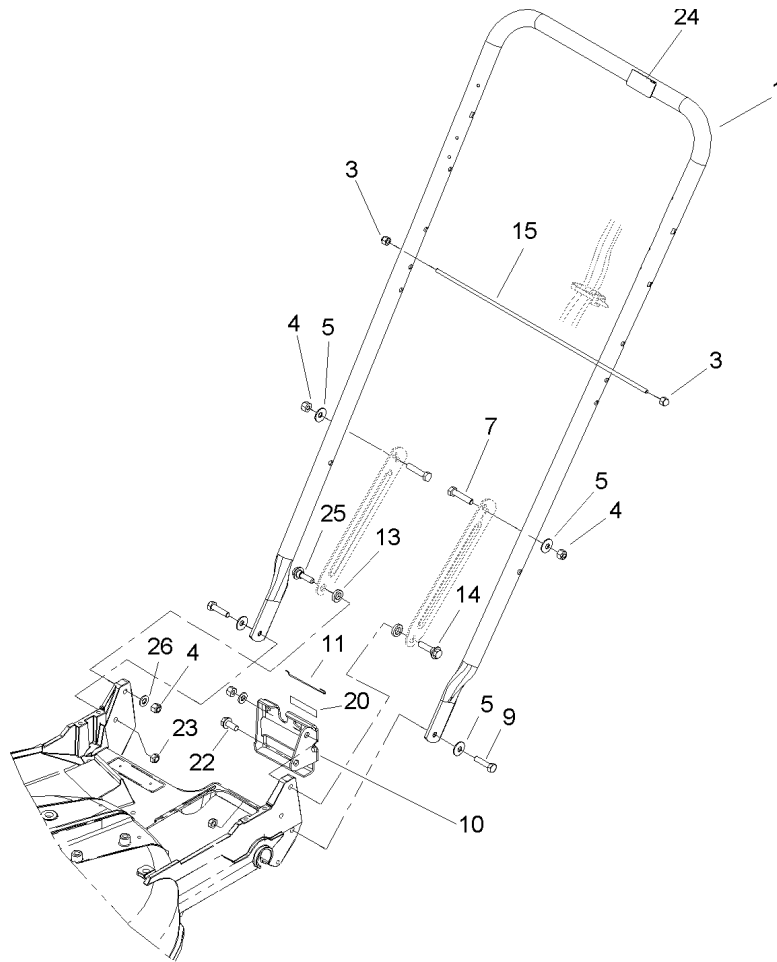

## Handle Assembly

Ref	Part No.	Qty.	Description
1	98-2385-03	1	Handle
3	32111-7	2	Nut-Cap
4	3296-29	4	Nut-Lock, NI
5	3290-456	4	Washer-Belleville
7	322-7	2	Screw-HH
9	322-6	2	Screw-HH
10	74-1741	1	Bracket-Adjustment, Traction
11	46-7030	1	Retainer-Cable
13	3-3287	2	Spacer-Latch, Handle
14	27-7210	1	Screw-Shoulder
15	48-2810	1	Rod-Support, Bag
20	74-1970	1	Decal-Position, Gear
22	32144-70	1	Screw-HH
23	3296-47	2	Nut-Lock, NI
24	104-1329	1	Decal-Protection, Hearing
25	27-7211	1	Screw-Shoulder
26	3256-23	2	Washer-Flat

--	--	--	--

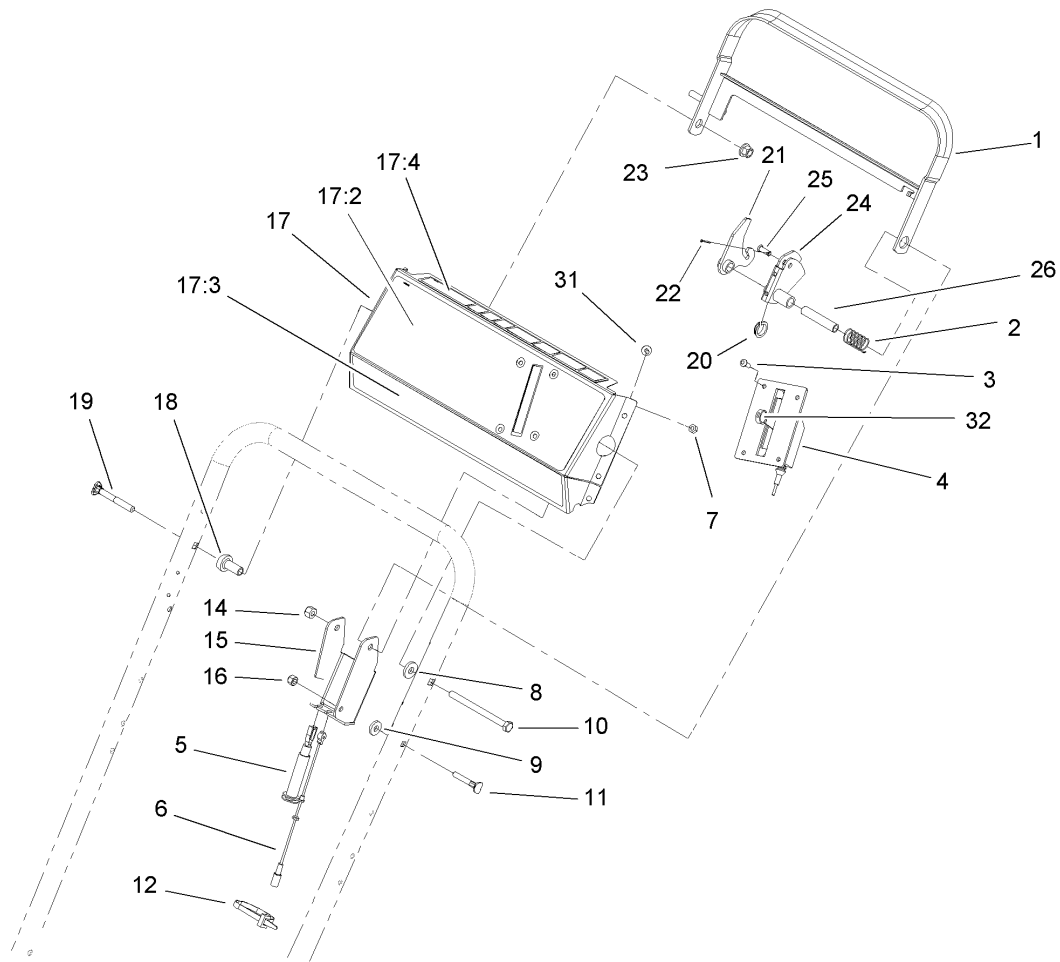

## Control Assembly

Ref	Part No.	Qty.	Description
1	84-8940-03	1	Bar-Control
2	85-6750	1	Spring-Control
3	3250-12	4	Screw-PPH
4	106-0857	1	Control-Throttle
5	84-9120	1	Cable-Traction
6	84-9110	1	Cable-Clutch
7	3296-2	4	Nut-Lock
8	71-9310	1	Spacer
9	71-9320	1	Spacer
10	322-19	1	Screw-HH
11	46-6430	1	Screw-Handle
12	3290-378	1	Tie-Cable
14	3296-29	1	Nut-Lock, NI
15	92-1778-03	1	Bracket-Control
16	3296-42	1	Nut-Lock, NI
17	100-6481	1	Panel-Control
17:2	100-3282	1	Decal-Panel, Control
17:3	1-213400	1	Decal-Console
17:4	104-8582	1	Decal-Panel, Danger
18	49-1631	1	Spacer-Support
19	17-9427	1	Screw
20	86-9320	1	Bushing-Flange
21	84-9000	1	Lever-Traction
22	3272-1	1	Pin-Cotter

Ref	Part No.	Qty.	Description
23	3296-58	1	Nut-Lock NI
24	84-8990	1	Lever-Bbc
25	84-9040	1	Pin-Cable
26	84-9030	1	Spacer-Bracket, Control
31	32104-76	6	Screw
32	233-35	1	Knob

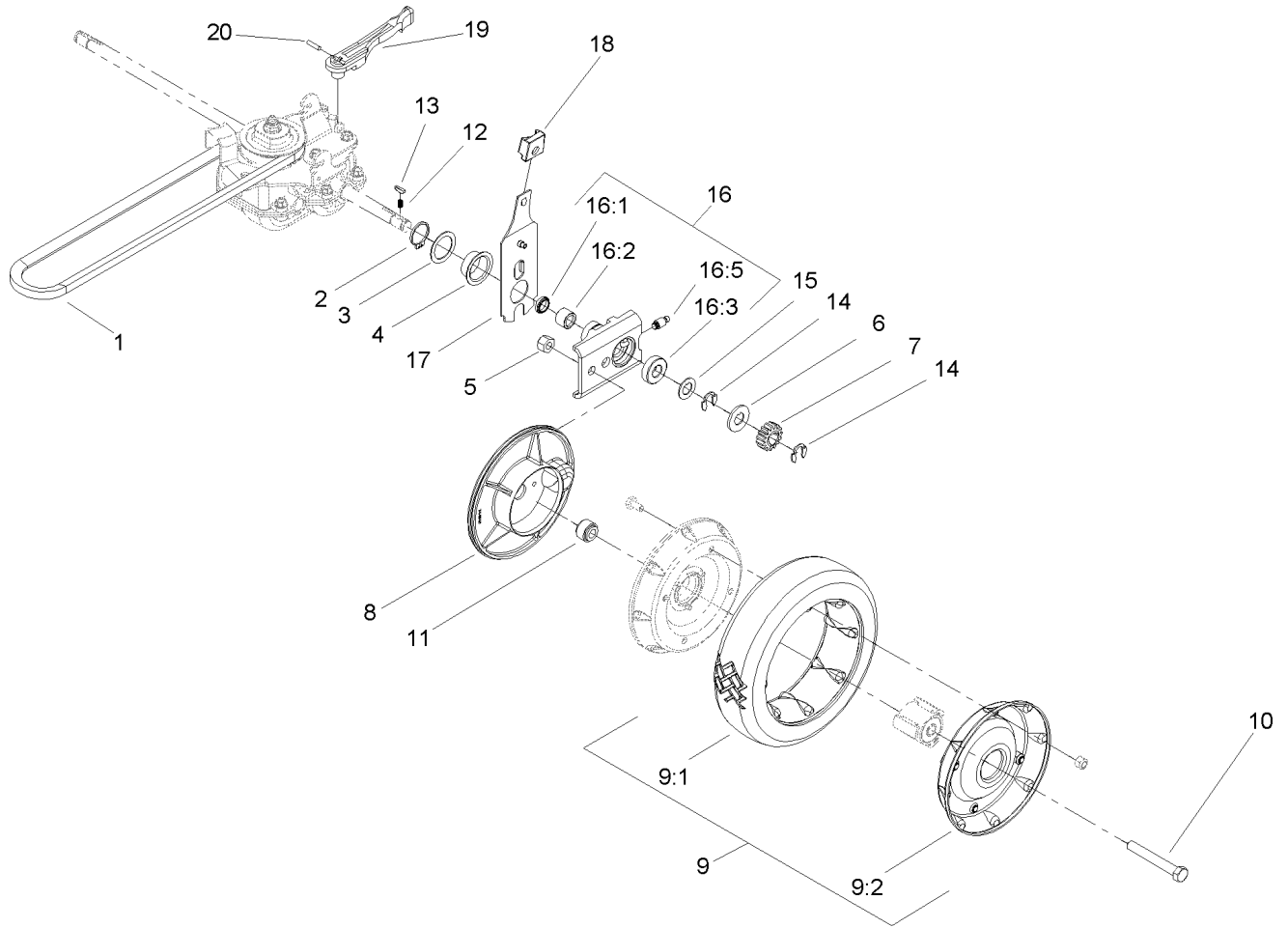

## Rear Axle and Transmission Assembly

Ref	Part No.	Qty.	Description
1	1-213237	1	V-Belt
2	32151-36	2	Ring-Retaining
3	74-1810	2	Washer
4	48-2170	2	Cap-End
5	32152-2	2	Nut-Hex
6	62-3830	2	Washer-Thrust, Outer
7	39-9160	2	Gear-Pinion
8	74-1640	2	Cover-Wheel
9	100-2860	2	Wheel And Tire ASM
9:1	53-7740	1	Tire
9:2		1	Wheel ASM
10	323-13	2	Screw-HH
11	74-1650	2	Spacer-Cover, Wheel
12	39-9650	2	Spring-Compression
13	612066	2	Key
14	32151-68	4	Ring-Retaining
15	49-7700	2	Washer-Thrust, Outer
16	74-1851	2	Pivot Arm ASM
16:1	47-6730	1	Seal-Oil
16:2	48-2060	1	Bearing-Roller
16:3	52-2450	1	Bearing-Wheel
16:5	92-6316	1	Zerk
17	66-7561	2	Rear Spring Arm ASM
18	25-7740	2	Knob-Arm

Ref	Part No.	Qty.	Description
19	74-1960	1	Lever-Shift
20	32121-99	1	Pin-Coil
99	100-2512	1	Tube-Drain, Oil
99	100-2886	1	Grass Bag ASM

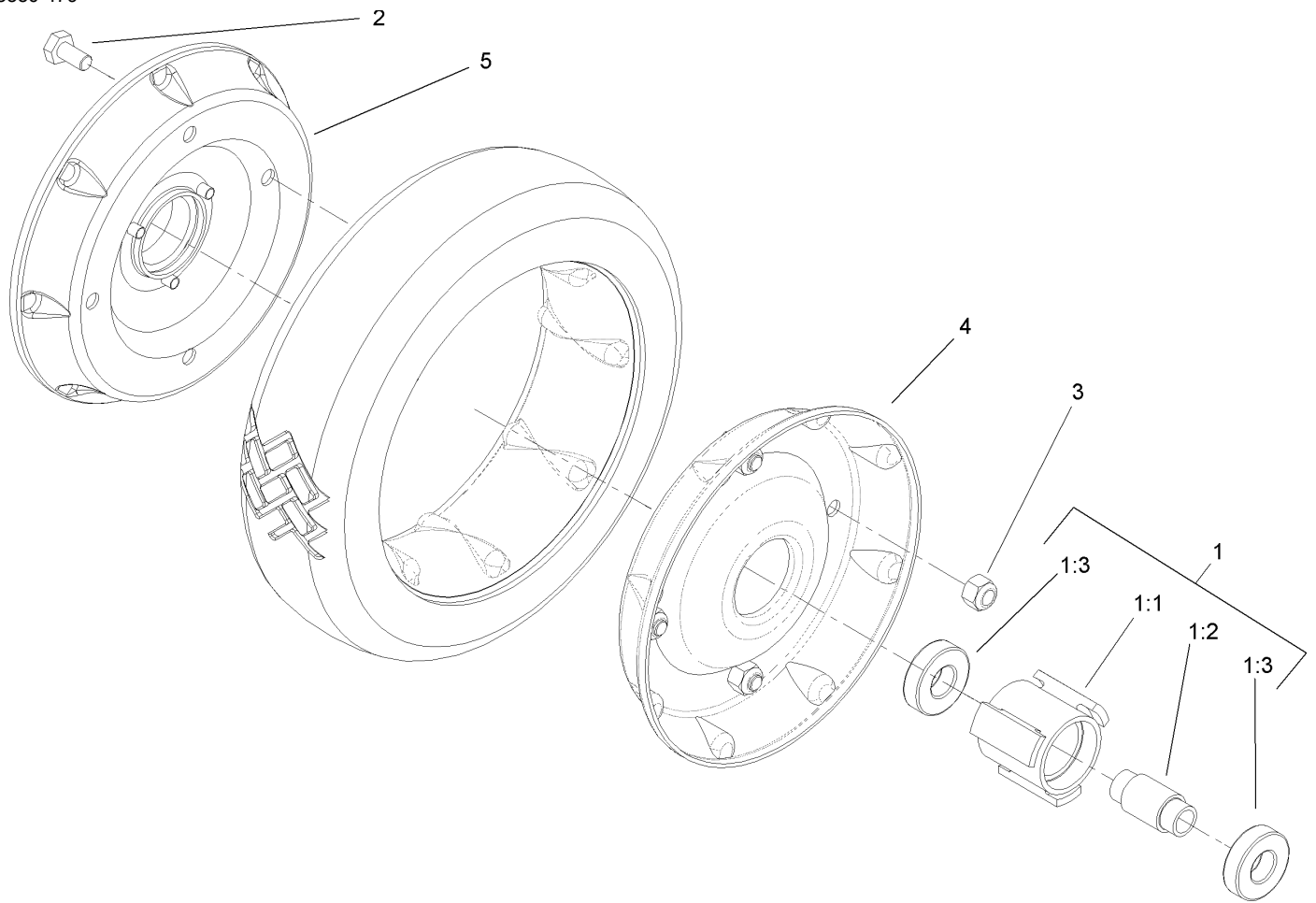

## Rear Wheel Assembly

Ref	Part No.	Qty.	Description
1		1	Hub And Bearing ASM
1:1	52-2410	1	Hub-Bearing
1:2	52-2440	1	Spacer-Bearing
1:3	52-2450	2	Bearing-Wheel
2	321-2	4	Screw-HH
3	3296-42	4	Nut-Lock, NI
4	53-7780-06	1	Plate-Wheel, Half
5	92-4957-06	1	Wheel Half/gear ASM

--	--	--	--

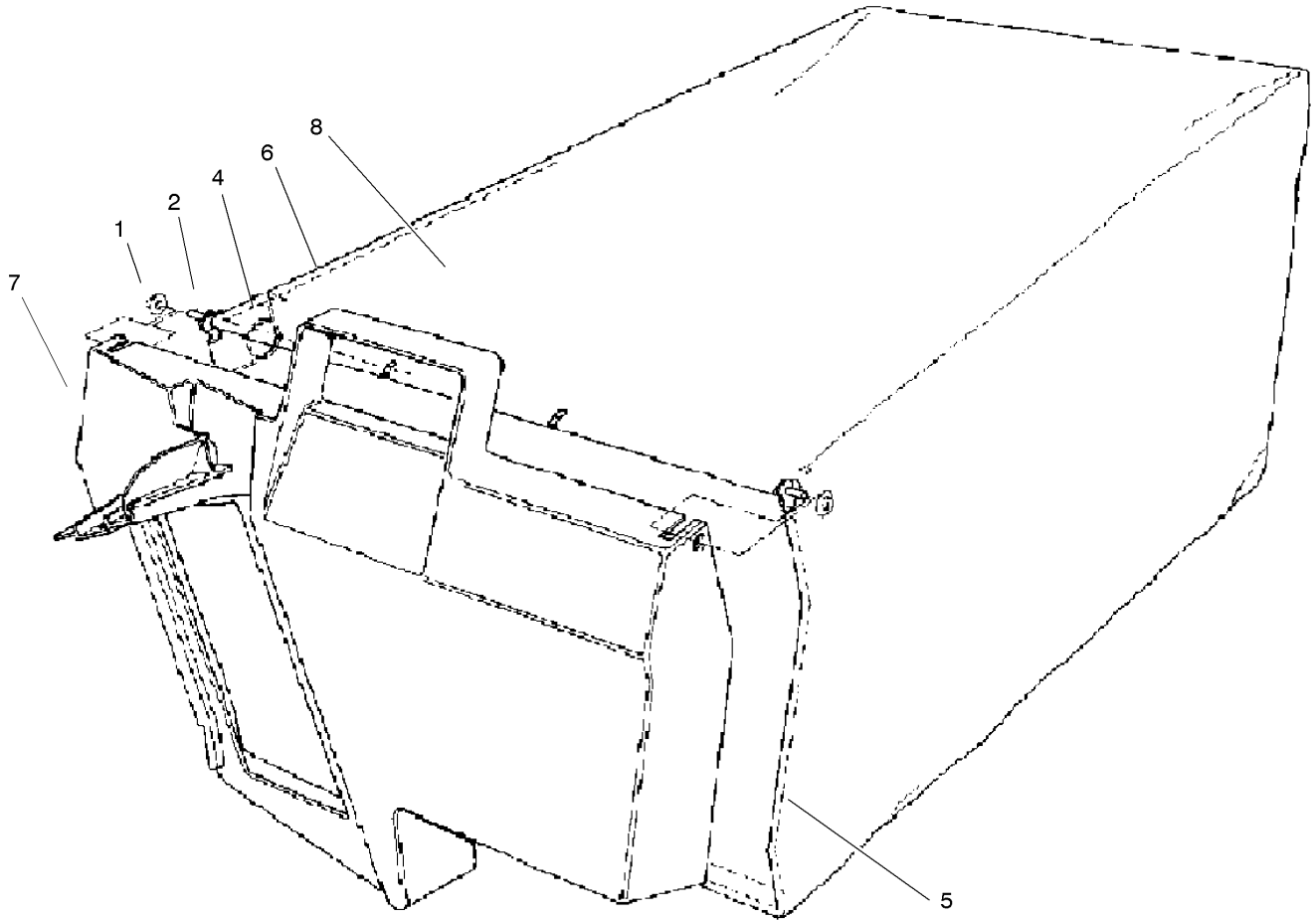

### Grass Bag Assembly No. 100-2886

Ref	Part No.	Qty.	Description
1	3290-422	2	Nut-Push
2	33-4820	1	Hinge-Door, Bag
4	36-6910	2	Spring
5	42-4020	1	Frame-Bag
6	42-4030	1	Frame-Bag, Upper
7	48-2840	1	Door-Bag, Grass
8	98-8017	1	Bag-Grass

--	--	--	--

## NOTES

**SEE EXMARK'S COMPLETE  
LINE OF PRODUCTS FOR TURF CARE**

**LAZER Z<sup>®</sup>**

**LAZER Z<sup>®</sup> HP**

**LAZER Z<sup>®</sup> XP**

**LAZER Z<sup>®</sup> CT**

**TURF RANGER<sup>®</sup>**

**VIKING HYDRO**

**TURF TRACER<sup>®</sup>**

**TURF TRACER<sup>®</sup> HP**

**METRO<sup>®</sup>**

**METRO<sup>®</sup> HP**

**ULTRA VAC<sup>™</sup>**

**ULTRA VAC<sup>™</sup> QDS**

**GRASS CATCHER**

**MICRO-MULCH<sup>™</sup> ACCESSORY**

**SELF STEERING SULKY**

©1997 - 2003  
EXMARK MFG. CO. INC.  
INDUSTRIAL PARK BOX 808  
BEATRICE, NE 68310  
ALL RIGHTS RESERVED

PART NO. 3350-479  
(402) 223-6300  
FAX (402) 223-5489  
PRINTED IN U.S.A.

