

M216HSP

For Serial Nos.  
440,000 & Higher



PARTS MANUAL

# METRO<sup>®</sup> 21

**CONGRATULATIONS** on the purchase of your new Exmark mower. This product has been carefully designed and manufactured to give you a maximum amount of dependability and years of trouble-free operation. If additional information is needed, or should you require trained mechanic service, contact your authorized Exmark equipment dealer or distributor. If you need to order replacement parts from your dealer, always give the model number and serial number of your mower as well as the part number, description and quantity of the part needed.

The Serial No. plate is located on the top of the mower deck on the right hand corner of the machine. For ease of ordering and reference, we suggest that you record the information requested in the following identification table.

Place Model No. and Serial No. Label Here (Included in Literature Pack) or Fill in Below
Model No. _____
Serial No. _____

Engine Model No. and Spec. No. (Code) \_\_\_\_\_

Engine Serial No. (E/No) \_\_\_\_\_

Date Purchased \_\_\_\_\_

# EXMARK PARTS PLUS® PROGRAM

EFFECTIVE DATE: September 1, 1995

## Program

If your Exmark dealer does not have the Exmark part in stock, Exmark will get the parts to the dealer the next business day or the part will be FREE\* Guaranteed!!

## *How the Program Works*

1. If dealer does not have part in stock for a "down" unit at the time of request by customer, the dealer contacts his distributor by 1:00 p.m., local time, and requests Exmark Parts Plus® shipment of six (6) line items or less.
2. Distributor ships part(s) to dealer or customer, as requested by dealer, same day, overnight UPS. Distributor bills dealer for part and freight charges where applicable.
3. If distributor does not have the part(s) in stock to satisfy Exmark Parts Plus® order, he contacts Exmark by 3:00 p.m., central time, with an Exmark Parts Plus® order of six (6) line items or less.
4. If order is received by 3:00 p.m. central time, Exmark ships part(s) direct to dealer or customer, as requested by distributor, same day, overnight UPS, Exmark bills the distributor for parts and shipping charges, where applicable.
5. The customer pays for the part and freight if it is shipped under the Exmark Parts Plus® and if it arrives in accordance to the program.
6. Who pays for the part and freight if it fails to arrive overnight in accordance to the program?
  - A. Under any circumstance the customer does not pay.
  - B. If the part does not arrive overnight due to:
    1. The dealer not submitting the Exmark Parts Plus® order to his Exmark distributor by 1:00 p.m., the dealer pays for the part and freight.
    2. The Distributor being unable to ship the part the same day or not submitting the Exmark Parts Plus® order to Exmark by 3:00 p.m., central time, the Distributor pays for the part and freight.
    3. Exmark being unable to ship the part and the Exmark parts order is received by 3:00 p.m., central time, Exmark pays for the part and freight.
    4. If the part does not arrive overnight due to the shipper (UPS), the shipper pays for the freight and Exmark pays for the part.

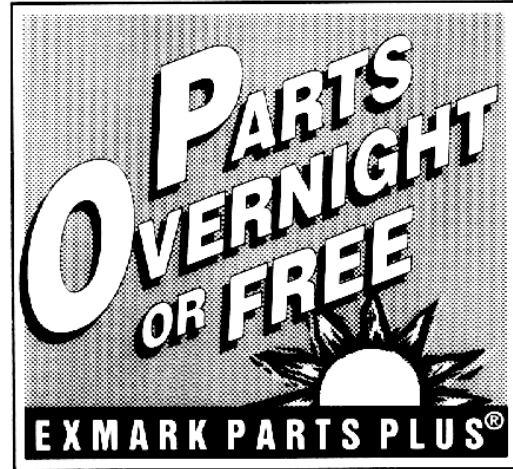

**The following restrictions apply** -- The Exmark Parts Plus® Program is available only through participating Exmark Dealers and applies only to orders submitted on this program Monday through Thursday. Parts Plus service is available only in the 48 contiguous United States. UPS has initiated a Saturday delivery program to many areas of the continental United States and can be requested for an overnight shipment on Friday to be delivered Saturday. The next day air charge, plus the Saturday delivery fee will be the responsibility of the purchaser. Exmark Mfg. will assume no responsibility for Saturday delivery shipments. To qualify, all Exmark Parts Plus® orders must be received by Exmark by 3:00 p.m., central time. Orders must be six (6) line items or less. Exclusions from the Exmark Parts Plus® Program are: Any wholegood or accessory in its entirety, engines and engine replacement parts, 5-speed Peerless transmissions and 5-speed transaxles, hydraulic or hydrostatic wheel motors, cutter decks and engine decks or any item exceeding United Parcel Service size and weight restrictions.

Due to UPS restrictions, aerosol spray paint is considered a hazardous material and cannot be shipped via UPS next day or Second Day Air.

Exmark Manufacturing stocks a limited supply of parts for transaxles, pumps and wheel motors. These parts can be ordered for Next Day Air shipment but will not be guaranteed per the Parts Plus Program



**READ OPERATOR'S MANUAL BEFORE  
OPERATING OR SERVICING EXMARK EQUIPMENT.**

**TABLE OF CONTENTS**

Deck, Discharge Tunnel and Wheel Assembly	..... 4
Wheel and Tire Assembly Part No. 53-7720	..... 6
Gear Case Assembly No. 74-1861	..... 7
Engine and Blade Mounting Assembly	..... 8
Handle and Control Assembly	..... 9
Gearcase and Rear Wheel Assembly	..... 10
Rear Wheel Assembly	..... 11
Grass Bag Assembly No. 100-2886	..... 12

**Part Description Abbreviations**

Part descriptions in this catalog may include the following abbreviations.

AR. .... as required	HYD. .... hydraulic
ASM. .... assembly	INC. .... incorporated
CARR. .... carriage	LH. .... left hand
DEG. .... degrees	NI. .... nylon insert
FH. .... flat head	PPH. .... phillips pan head
GA. .... gauge	PTH. .... phillips truss head
HF. .... hex flange	PTO. .... power take off
HH. .... hex head	RH. .... right hand
HHF. .... hex head flange	SFH. .... slotted fillister head
HHFTF. .... hex head flange thread forming	SHH. .... slotted hex head
HJ. .... hex jam	SHWH. .... slotted hex washer head
HLH. .... hex lag head	SPH. .... slotted pan head
HOC. .... height-of-cut	SQH. .... square head
HS. .... hex	SRH. .... slotted round head
HSBH. .... hex socket button head	STD. .... standard
HSFH. .... hex socket flat head	TAP. .... self tapping
HSH. .... hex socket head	TTH. .... torx truss head
HWH. .... hex washer head	WH. .... wing head
HWHTF. .... hex washer head thread forming	

**Footnotes**

❶ Not illustrated

❷ Not serviced separately

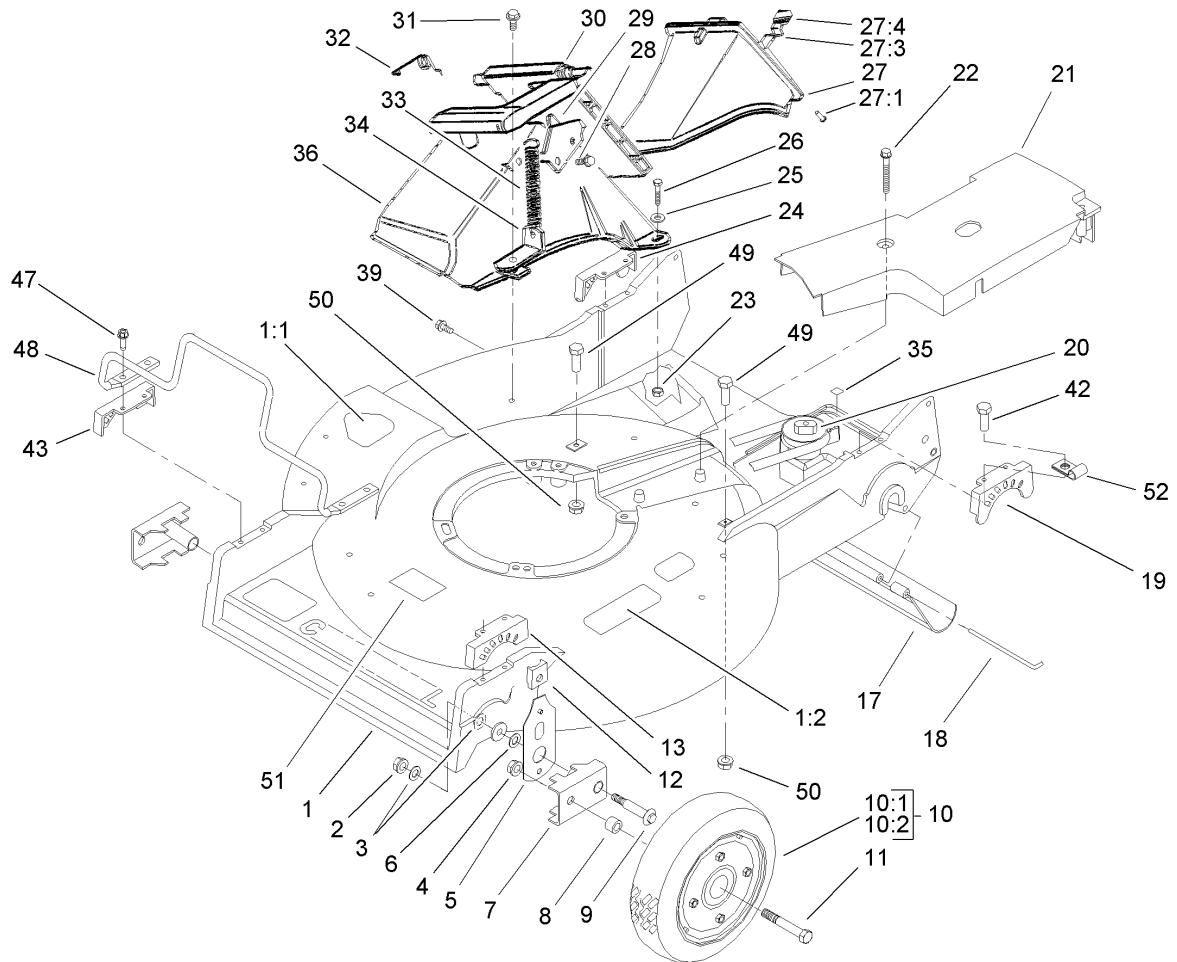

## Deck, Discharge Tunnel and Wheel Assembly

Ref	Part No.	Qty.	Description
1	98-8027	1	Housing ASM
1:1	39-5770	1	Decal-Danger
1:2	104-8585	1	Decal-Warning
2	3296-6	2	Nut-Lock, NI
3	40-1940	4	Washer
4	32152-2	2	Nut-Hex
5	66-7560	2	Front Spring Arm ASM
6	257-3	2	Washer-Thrust
7	61-8300	2	Arm-Pivot, Front
8	52-2480	2	Spacer-Wheel
9	27-6232	2	Bolt-Wheel
10	100-2870	2	Wheel And Tire ASM
10:1	53-7740	1	Tire
10:2		1	Wheel ASM
11	323-12	2	Screw-HH
12	25-7740	2	Knob-Arm
13	49-8760	1	Quadrant-Front, LH
17	44-0580	1	Shield-Trailing
18	33-3208	1	Rod-Shield
19	49-8740	1	Quadrant-Rear, LH
20	74-1861	1	Gear Case ASM
21	74-1770	1	Cover-Belt
22	37-7260	2	Screw-HH
23	3296-42	2	Nut-Lock, NI

Ref	Part No.	Qty.	Description
24	49-8750	1	Quadrant-Rear, RH
25	3256-22	2	Washer-Flat
26	321-7	2	Screw-HH
27	77-0500	1	Discharge Plug ASM
27:1	3295-35	1	Rivet-Head, Flat
27:3	76-4640	1	Latch-Plug, Discharge
27:4	76-4650	1	Grip-Latch
28	46-8090	2	Screw-Plastite
29	93-3154	1	Latch-Plate
30	93-7351	1	Discharge Door ASM
31	46-6811	1	Screw-HWH
32	80-3770	1	Retainer-Door
33	76-4660	1	Spring-Door
34	71-9350	1	Bracket-Spring
35	52-2620	1	Label-Grease
36	82-9152	1	Tunnel-Discharge
39	46-6810	1	Screw And Washer ASM
42	49-2040	4	Screw-Tapping
43	49-8770	1	Quadrant-Front, RH
47	32144-86	4	Screw-Hwh, Thread Forming
48	99-6722	1	Guard-Engine
49	323-6	2	Screw-HH
50	3296-39	2	Nut-Lock, NI
51	68-7410	1	Decal-Blade

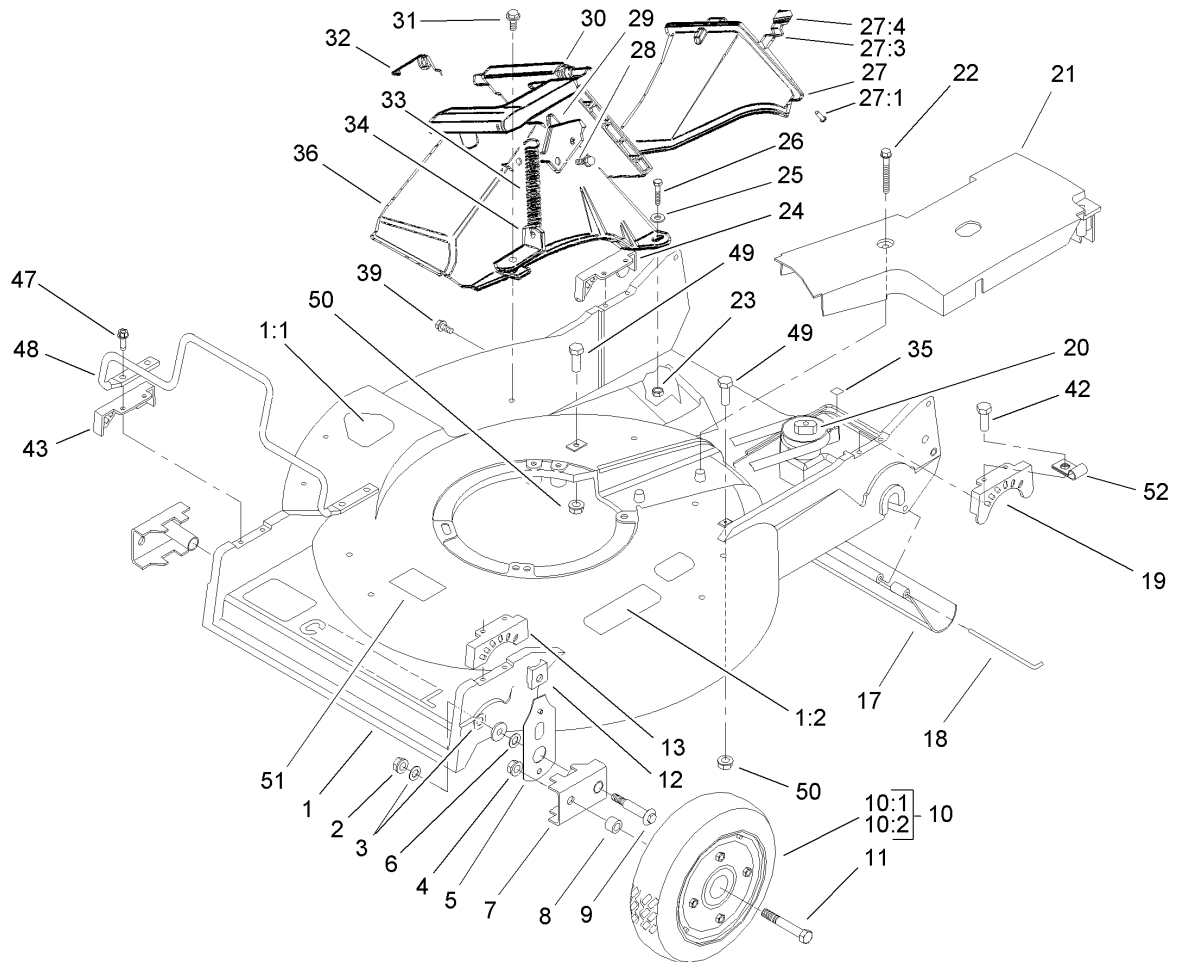

### Deck, Discharge Tunnel and Wheel Assembly (continued)

Ref	Part No.	Qty.	Description
52	2412-72	1	Clip-Closed, Insulated

Ref	Part No.	Qty.	Description
-----	----------	------	-------------

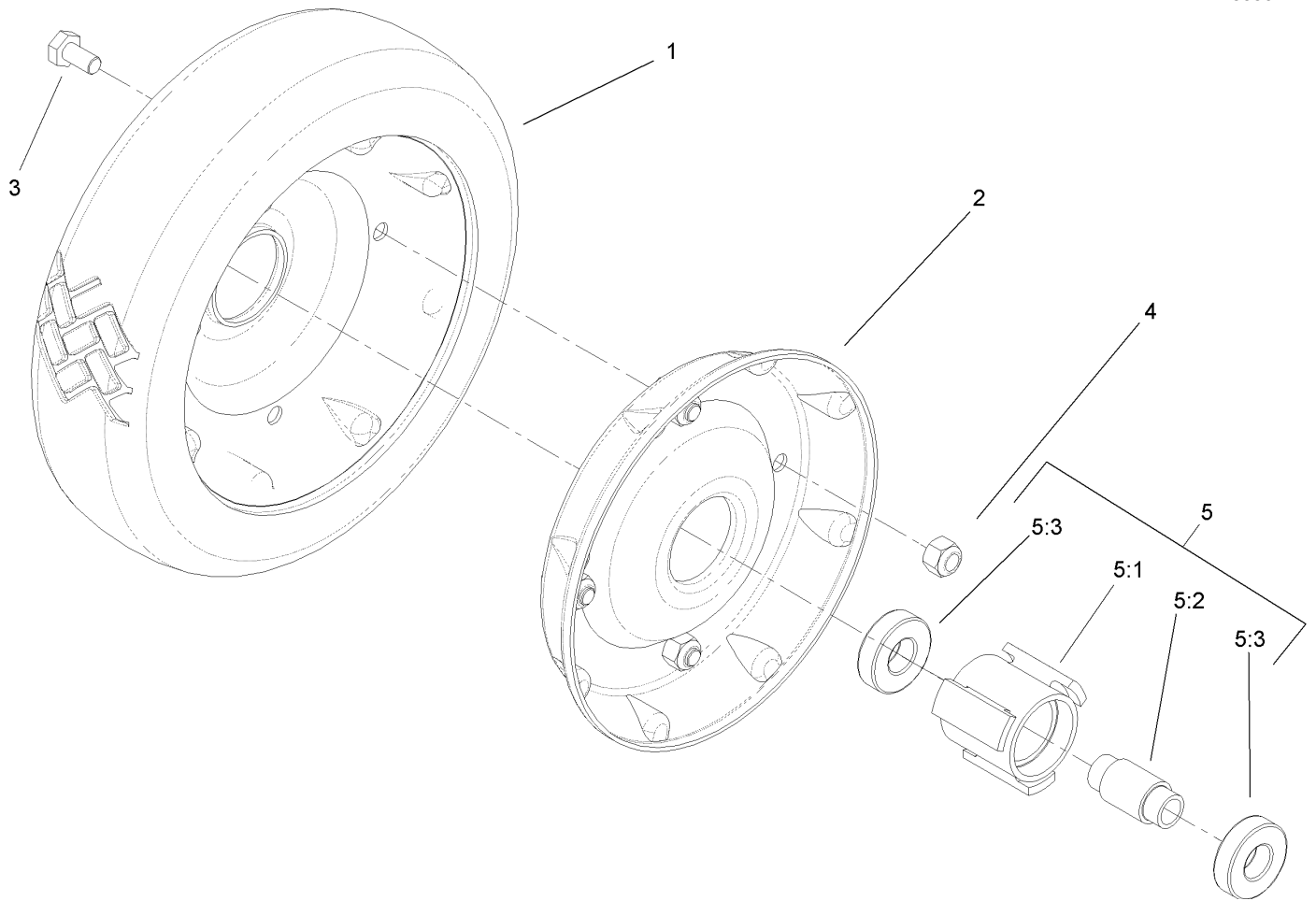

### Wheel and Tire Assembly Part No. 53-7720

Ref	Part No.	Qty.	Description				
1	53-7740	1	Tire				
2	53-7780-06	2	Plate-Wheel, Half				
3	321-2	4	Screw-HH				
4	3296-42	4	Nut-Lock, NI				
5		1	Hub And Bearing ASM				
5:1	52-2410	1	Hub-Bearing				
5:2	52-2440	1	Spacer-Bearing				
5:3	52-2450	2	Bearing-Wheel				

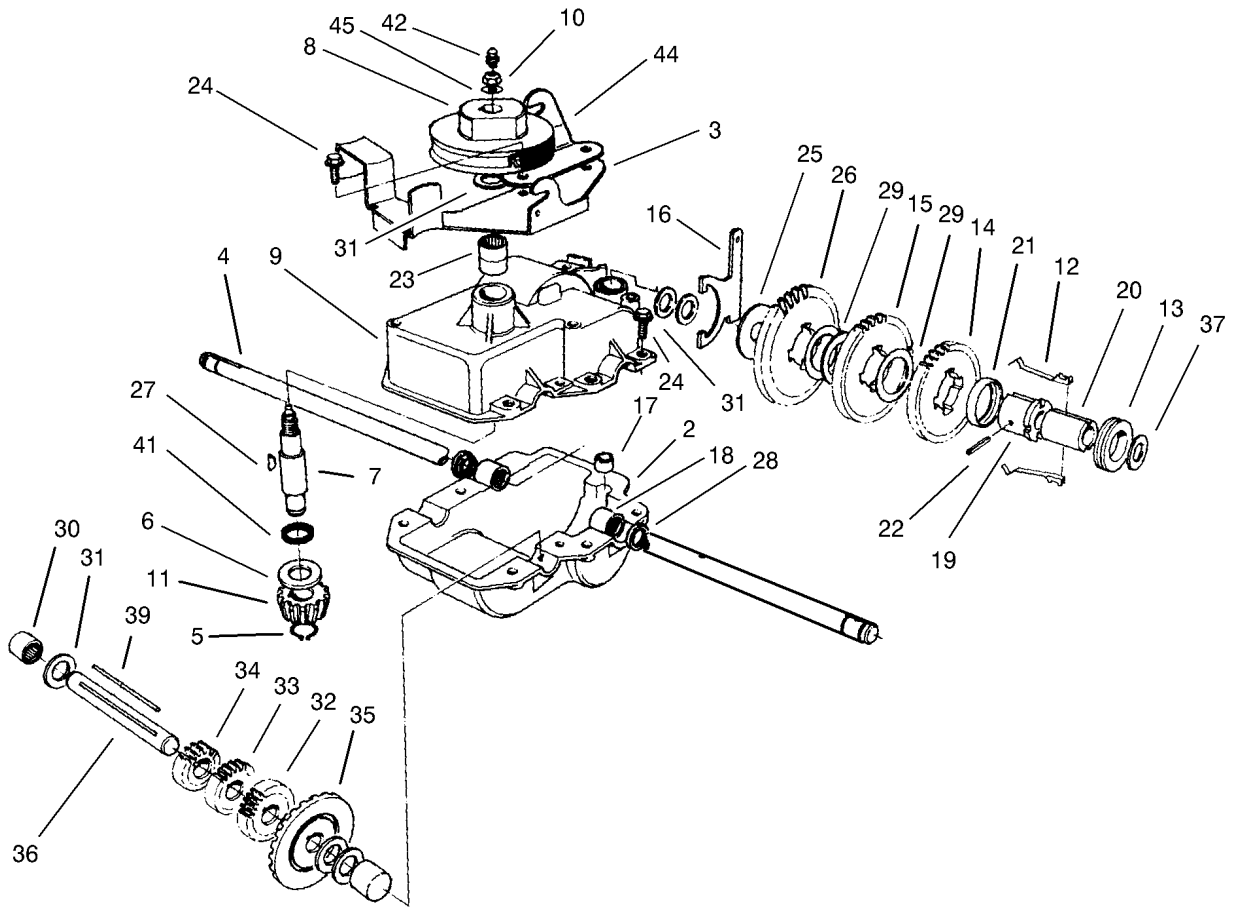

### Gear Case Assembly No. 74-1861

Ref	Part No.	Qty.	Description
2	74-1920	1	Case-Gear, Lower
3	49-8461-03	1	Bracket-Guide, Belt
4	74-1890	1	Shaft-Output
5	32151-57	1	Ring-Retaining
6	47-2910	1	Washer-Thrust
7	68-8190	1	Shaft-Input
8	39-6740	1	Pulley
9	74-1880	1	Case-Gear, Upper
10	3296-5	1	Nut-Lock, NI
11	39-6660	1	Pinion-Bevel
12	29-9330	2	Key-Shift
13	29-9340	1	Collar-Shift
14	42-4740	1	Gear-38 Tooth
15	29-9271	1	Gear-42 Tooth
16	60-8870	1	Yoke-Shift
17	29-9570	1	Bushing-Yoke
18	47-6730	2	Seal-Oil
19	55-8010	1	Sleeve-Gear
20	39-6720	1	Sleeve
21	55-8020	1	Retainer-Key
22	3285-19	1	Pin-Groove
23	47-7270	2	Bearing
24	49-2040	6	Screw-Tapping
25	29-9690	1	Washer

Ref	Part No.	Qty.	Description
26	46-3560	1	Gear
27	3257-1	2	Key-Woodruff
28	48-2060	2	Bearing-Roller
29	36-4770	3	Washer
30	252-103	2	Bearing-Closed
31	36-4792	4	Washer-Thrust
32	39-6650	1	Gear-18t
33	46-3550	1	Gear-14t
34	46-3540	1	Gear-12t
35	74-1760	1	Gear-Bevel
36	53-7950	1	Shaft-Intermediate
37	36-4780	3	Washer
39	39-7842	1	Key
41	47-7260	1	Seal
42	302-63	1	Zerk
44	74-1750-03	1	Brake-Engage, Traction
45	3256-45	1	Washer-Flat

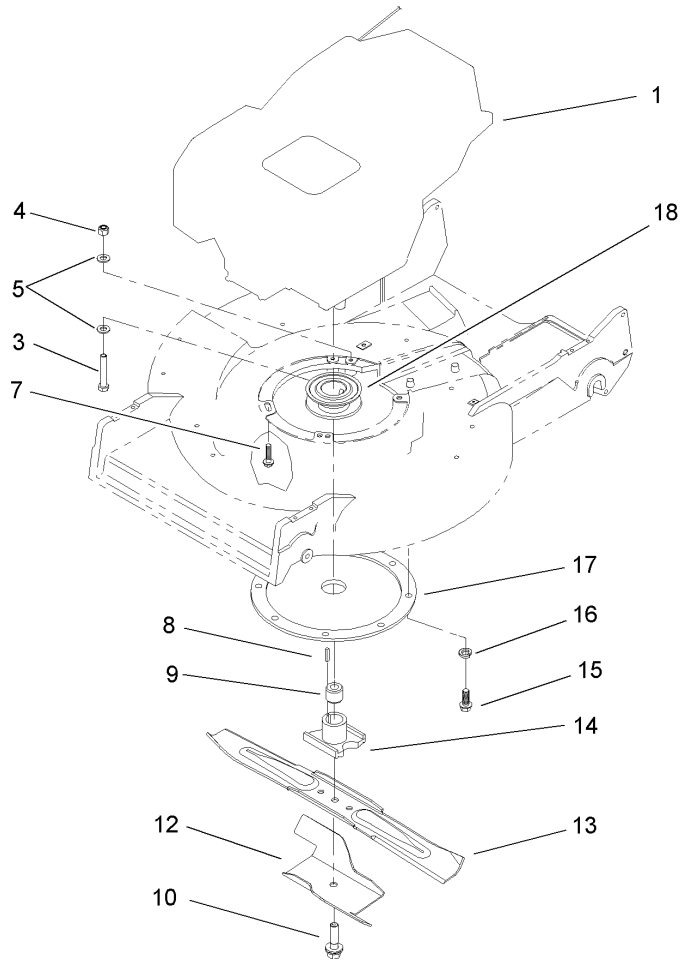

## Engine and Blade Mounting Assembly

Ref	Part No.	Qty.	Description				
1		1	Engine-Honda, Gxv 160k1a1t				
3	322-10	1	Screw-HH				
4	3296-29	1	Nut-Lock, NI				
5	3256-23	2	Washer-Flat				
7	103-2678	3	Screw-Shoulder				
8	5-1077	1	Key-Square				
9	103-3795	1	Spacer-Retainer, Blade				
10	105-8579	1	Bolt-Blade				
12	92-1599-03	1	Stiffener-Blade				
13	42-1000-03	1	Blade				
14	52-2170-03	1	Retainer-Blade				
15	32144-70	3	Screw-HH				
16	3254-6	3	Washer-Lock, Internal				
17	65-5860	1	Protector-Crankshaft				
18	46-7910	1	Pulley-Driver				



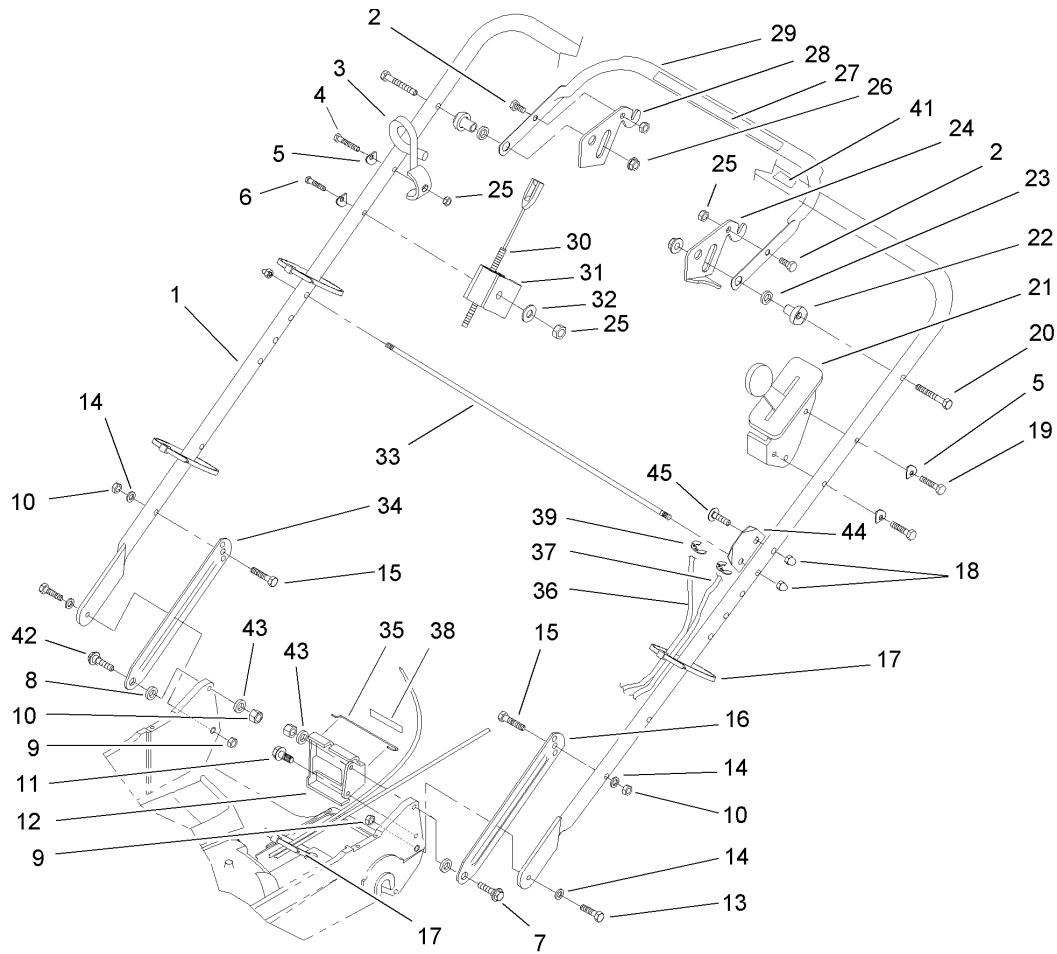

## Handle and Control Assembly

Ref	Part No.	Qty.	Description
1	98-2000-03	1	Handle
2	321-4	2	Screw-HH
3	46-8081	1	Guide-Rope
4	321-9	1	Screw-HH
5	3-7501	4	Washer
6	321-15	1	Screw-HH
7	27-7210	1	Screw-Shoulder
8	3-3287	2	Spacer-Latch, Handle
9	3296-47	2	Nut-Lock, NI
10	3296-29	5	Nut-Lock, NI
11	32144-70	1	Screw-HH
12	74-1741	1	Bracket-Adjustment, Traction
13	322-6	2	Screw-HH
14	3290-456	4	Washer-Belleville
15	322-7	2	Screw-HH
16	103-0143	1	Latch-Handle, LH
17	3290-378	4	Tie-Cable
18	32111-7	3	Nut-Cap
19	321-13	2	Screw-HH
20	322-11	2	Screw-HH
21	103-5296	1	Control-Throttle
22	49-1630	2	Spacer-Support
23	256-276	2	Spacer-Nylon
24	66-5350	1	Lever-Control

Ref	Part No.	Qty.	Description
25	3296-42	4	Nut-Lock, NI
26	3296-58	2	Nut-Lock NI
27	1-213242	1	Decal-Traction
28	77-5270	1	Lever-Control
29	61-8270-03	1	Bar-Control
30	103-2683	1	Cable-Brake
31	46-6980	1	Support-Cable
32	3256-22	1	Washer-Flat
33	48-2810	1	Rod-Support, Bag
34	103-0142	1	Latch-Handle, RH
35	46-7030	1	Retainer-Cable
36	74-1791	1	Cable-Traction
37	106-0888	1	Throttle Cable ASM
38	74-1970	1	Decal-Position, Gear
39	32151-86	2	E-Ring
41	104-1329	1	Decal-Protection, Hearing
42	27-7211	1	Screw-Shoulder
43	3256-23	4	Washer-Flat
44	104-1326	1	Plate-Aligning, Bag
45	3229-3	1	Screw-CARR

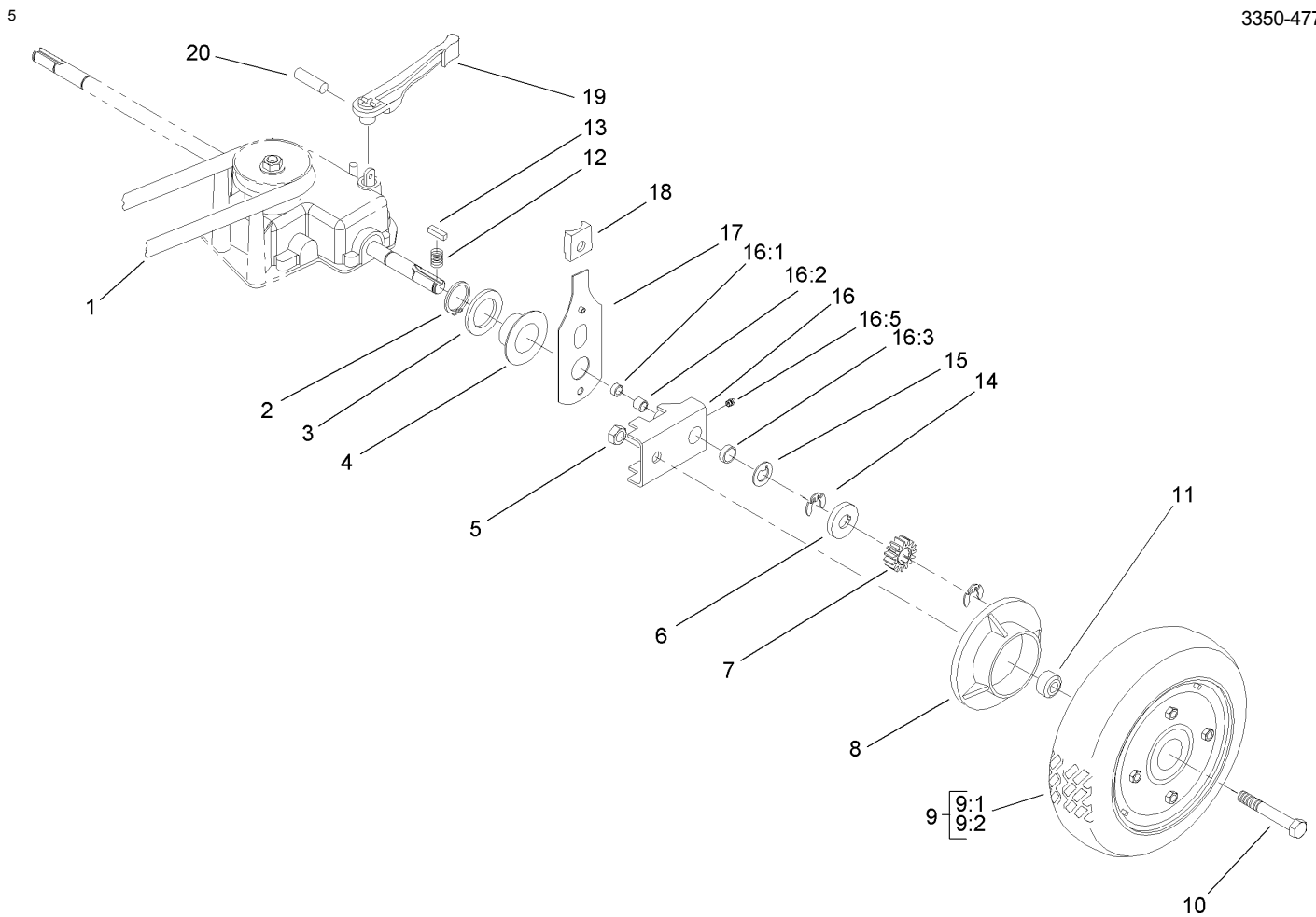

## Gearcase and Rear Wheel Assembly

Ref	Part No.	Qty.	Description
1	1-213237	1	V-Belt
2	32151-36	2	Ring-Retaining
3	74-1810	2	Washer
4	48-2170	2	Cap-End
5	32152-2	2	Nut-Hex
6	62-3830	2	Washer-Thrust, Outer
7	39-9160	2	Gear-Pinion
8	74-1640	2	Cover-Wheel
9	100-2860	2	Wheel And Tire ASM
9:1	53-7740	1	Tire
9:2		1	Wheel ASM
10	323-13	2	Screw-HH
11	74-1650	2	Spacer-Cover, Wheel
12	39-9650	2	Spring-Compression
13	612066	2	Key
14	32151-68	4	Ring-Retaining
15	49-7700	2	Washer-Thrust, Outer
16	74-1851	2	Pivot Arm ASM
16:1	47-6730	1	Seal-Oil
16:2	48-2060	1	Bearing-Roller
16:3	52-2450	1	Bearing-Wheel
16:5	92-6316	1	Zerk
17	66-7561	2	Rear Spring Arm ASM
18	25-7740	2	Knob-Arm

Ref	Part No.	Qty.	Description
19	74-1960	1	Lever-Shift
20	32121-99	1	Pin-Coil
99	100-2886	1	Grass Bag ASM

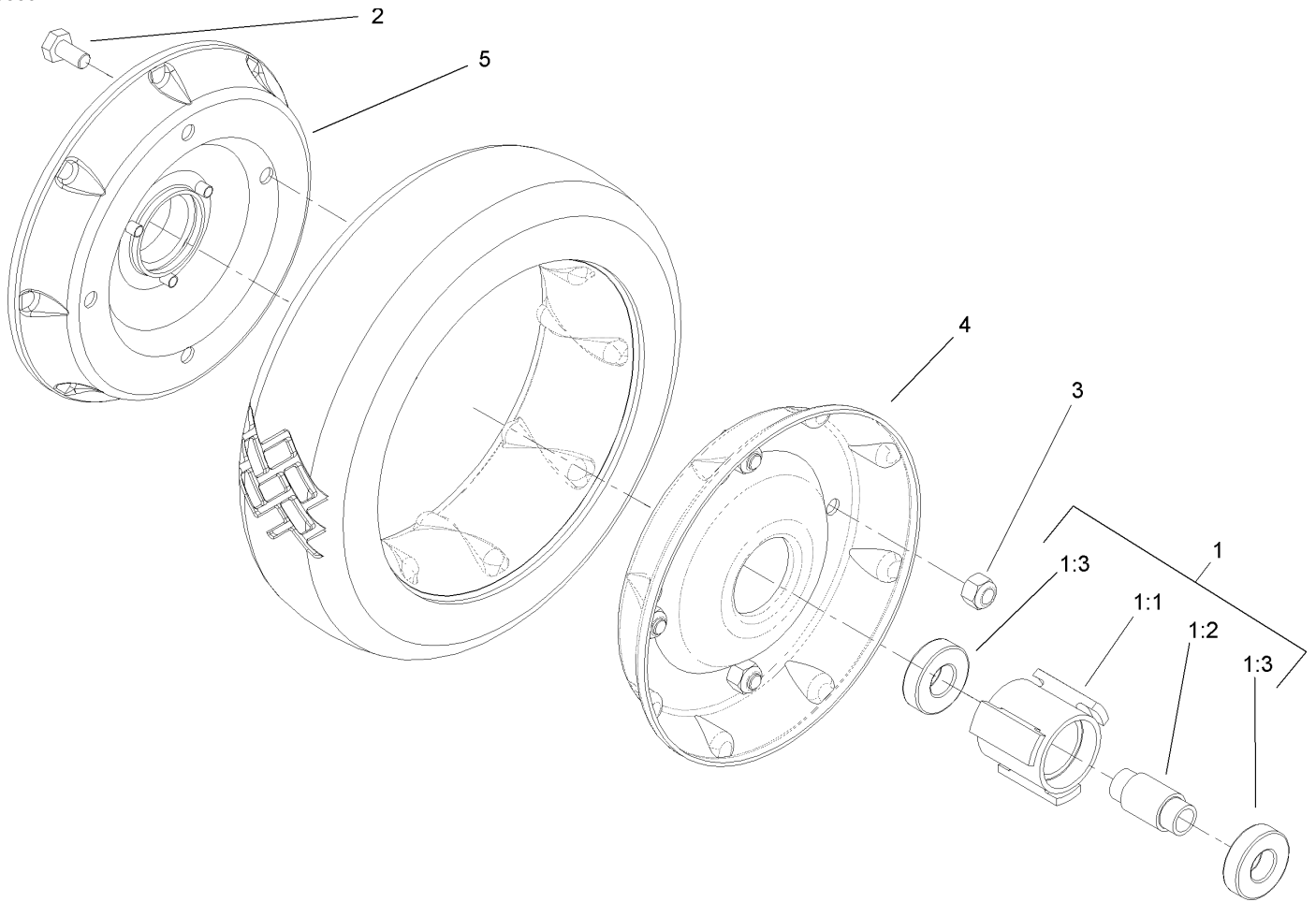

## Rear Wheel Assembly

Ref	Part No.	Qty.	Description
1		1	Hub And Bearing ASM
1:1	52-2410	1	Hub-Bearing
1:2	52-2440	1	Spacer-Bearing
1:3	52-2450	2	Bearing-Wheel
2	321-2	4	Screw-HH
3	3296-42	4	Nut-Lock, NI
4	53-7780-06	1	Plate-Wheel, Half
5	92-4957-06	1	Wheel Half/gear ASM

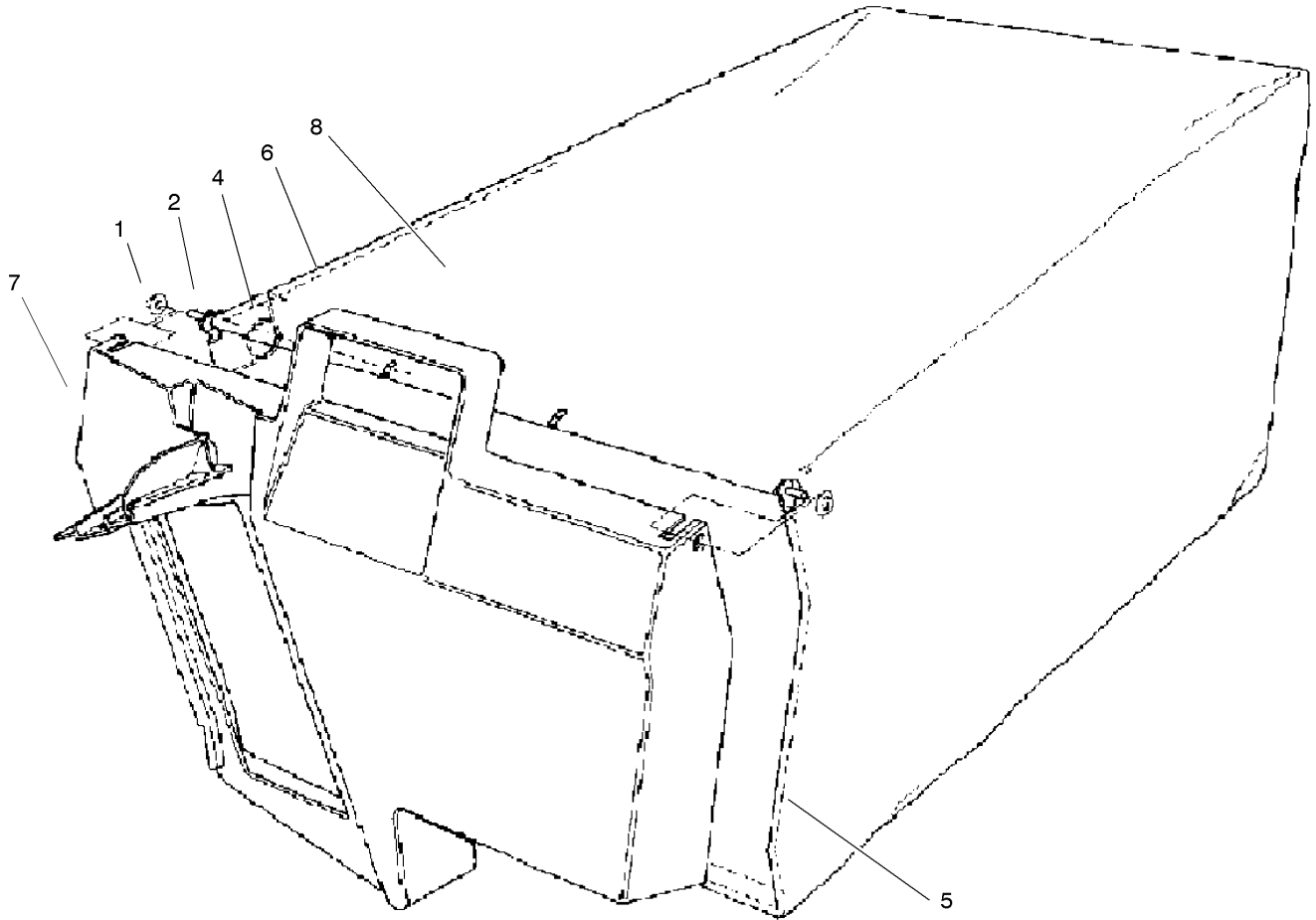
### Grass Bag Assembly No. 100-2886

Ref	Part No.	Qty.	Description
1	3290-422	2	Nut-Push
2	33-4820	1	Hinge-Door, Bag
4	36-6910	2	Spring
5	42-4020	1	Frame-Bag
6	42-4030	1	Frame-Bag, Upper
7	48-2840	1	Door-Bag, Grass
8	98-8017	1	Bag-Grass

--	--	--	--

## NOTES

## NOTES

## NOTES

**SEE EXMARK'S COMPLETE  
LINE OF PRODUCTS FOR TURF CARE**

**LAZER Z<sup>®</sup>**

**LAZER Z<sup>®</sup> HP**

**LAZER Z<sup>®</sup> XP**

**LAZER Z<sup>®</sup> CT**

**TURF RANGER<sup>®</sup>**

**VIKING HYDRO**

**TURF TRACER<sup>®</sup>**

**TURF TRACER<sup>®</sup> HP**

**METRO<sup>®</sup>**

**METRO<sup>®</sup> HP**

**ULTRA VAC<sup>™</sup>**

**ULTRA VAC<sup>™</sup> QDS**

**GRASS CATCHER**

**MICRO-MULCH<sup>™</sup> ACCESSORY**

**SELF STEERING SULKY**

©1997 - 2004  
EXMARK MFG. CO. INC.  
INDUSTRIAL PARK BOX 808  
BEATRICE, NE 68310  
ALL RIGHTS RESERVED

PART NO. 3350-477  
(402) 223-6300  
FAX (402) 223-5489  
PRINTED IN U.S.A.

