

Lubricate Grease Fittings

Note: See chart for service intervals.

1. Stop engine, wait for all moving parts to stop, and remove key. Engage parking brake.
2. Lubricate fittings with one to two pumps of NGLI grade #2 multi-purpose gun grease.

Refer to the following chart for fitting locations and lubrication schedule.

Lubrication Chart			
Fitting Locations	Initial Pumps	Number of Places	Service Interval
1. Front Caster wheel hubs	*0	2	*Yearly
2. Front Caster Pivots	*0	2	*Yearly
3. Height Adjustment Shaft Bearings	1	5	40 Hours
4. Deck Drive Belt Idler Arm	1	1	Yearly
5. Brake Brackets	1	2	200 Hours
6. Mule Drive Belt Idler Arm	1	1	Yearly
7. Pump Drive Belt Idler Arm	1	1	Yearly
8. Deck Rear Struts	1	2	40 Hours

* See step 3 for special lubrication instructions on the front caster pivots and the **Lubricate Caster Wheel Hubs** section for special lubrication instructions on the front casters wheel hubs.

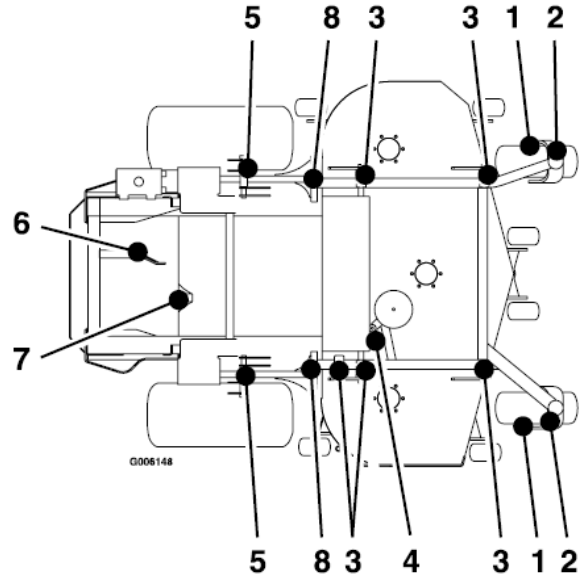

Number 6 (Mule Drive Belt Idler Arm) Located Under Engine Frame

Number 7 (Pump Drive Belt Idler Arm) Located Under Engine Frame

3. Lubricate front caster pivots once a year. Remove hex plug and cap. Thread grease zerk in hole and pump with grease until it oozes out around top bearing. Remove grease zerk and thread plug back in. Place cap back on.

Lubricate Caster Wheel Hubs

Service Interval: Yearly

1. Stop engine, wait for all moving parts to stop, and remove key. Engage parking brake.

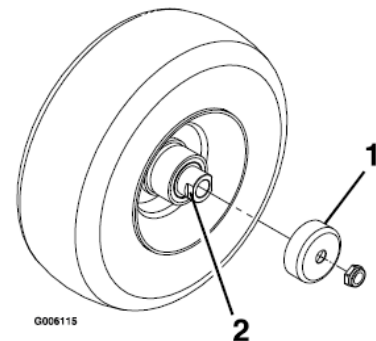

Figure 13

1. Seal guard
2. Spacer nut with wrench flats

2. Remove caster wheel from caster forks.
3. Remove seal guards from the wheel hub.

4. Remove one of the spacer nuts from the axle assembly in the caster wheel. Note that thread locking adhesive has been applied to lock the spacer nuts to the axle. Remove the axle (with the other spacer nut still assembled to it) from the wheel assembly.
5. Pry out seals, and inspect bearings for wear or damage and replace if necessary.
6. Pack the bearings with a NGLI grade #1 multi-purpose grease.
7. Insert one bearing, one new seal into the wheel.
Note: Seals (Exmark P/N 103-0063) must be replaced.
8. If the axle assembly has had both spacer nuts removed (or broken loose), apply a thread locking adhesive to one spacer nut and thread onto the axle with the wrench flats facing outward. Do Not thread spacer nut all of the way onto the end of the axle. Leave approximately 1/8 inch (3 mm) from the outer surface of the spacer nut to the end of the axle inside the nut.
9. Insert the assembled nut and axle into the wheel on the side of the wheel with the new seal and bearing.
10. With the open end of the wheel facing up, fill the area inside the wheel around the axle full of NGLI grade #1 multi-purpose grease.
11. Insert the second bearing and new seal into the wheel.
12. Apply a thread locking adhesive to the 2nd spacer nut and thread onto the axle with the wrench flats facing outward.
13. Torque the nut to 75-80 in-lb (8-9 N-m), loosen, then re-torque to 20-25 in-lb (2-3 N-m). Make sure axle does not extend beyond either nut.
14. Reinstall the seal guards over the wheel hub and insert wheel into caster fork. Reinstall caster bolt and tighten nut fully.

Important: To prevent seal and bearing damage, check the bearing adjustment often. Spin the caster tire. The tire should not spin freely (more than 1 or 2 revolutions) or have any side play. If the wheel spins freely, adjust torque on spacer nut until there is a slight amount of drag. Reapply thread locking adhesive.

Lubricate Brake Handle Pivot

Service Interval: Every 160 hours

1. Stop engine, wait for all moving parts to stop, and remove key. Engage parking brake.
2. Lubricate bronze bushings on brake handle pivot with a spray type lubricant or light oil.

Lubricate Brake Rod Bushings

Service Interval: Every 160 hours

1. Stop engine, wait for all moving parts to stop, and remove key. Engage parking brake.
2. Unhook seat latch and tilt seat up.
3. Lubricate bronze bushings on each end of brake rod shaft with a spray type lubricant or a light oil (bushings are located to the inside of the flange bearings).

Lubricate Motion Control Bronze Bushings

Service Interval: Every 160 hours

1. Stop engine, wait for all moving parts to stop, and remove key. Engage parking brake.
2. Unhook seat latch and tilt seat up.
3. Lubricate bronze bushings on flange bearings securing the motion control arm shafts with a light oil or a spray type lubricant.

Lubricate Seat Switch Actuator

Service Interval: Every 160 hours

1. Stop engine, wait for all moving parts to stop, and remove key. Engage parking brake.
2. Unhook seat latch and tilt seat up.
3. Lubricate switch actuator rod with spray type lubricant or light oil.